



# Assembly manual

# CANTILEVER S



 **CANTILEVER SE**



 **CANTILEVER S**



 **CANTILEVER SK**

# PRODUCT DEVELOPMENT PROCESS



A/DEON

SolidVision

AUTODESK

SOLIDWORKS

## SOLE SE 02

## SET

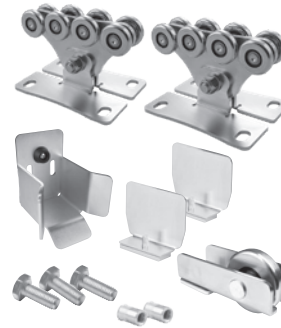

SPEED SE .....2 pcs  
 RUN S .....1 pc  
 LAST S .....1 pc  
 PILOT SN .....2 pcs  
 BOLT M10x25 .....15 pcs  
 RIVET NUT .....15 pcs

ART. SET / kg  
 SOLE SE 02 ..... 11,5 kg

GATES UP TO  
 WEIGHT .....325 kg

CODE: 1710018

## SOLE SE 03

## SET



SPEED SE .....2 pcs  
 RUN S .....1 pc  
 LAST S .....1 pc  
 PILOT SN .....2 pcs  
 FRS 2 .....1 pc  
 BOLT M10x25 .....15 pcs  
 RIVET NUT .....15 pcs

ART. SET / kg  
 SOLE SE 03 .....12,1 kg

GATES UP TO  
 WEIGHT .....325 kg

CODE: 1710019

## MARE S 02

## SET



SPEED S .....2 pcs  
 RUN S .....1 pc  
 LAST S .....1 pc  
 PILOT SN .....2 pcs  
 BOLT M10x25 .....15 pcs  
 RIVET NUT .....15 pcs

ART. SET / kg  
 MARE S 02 .....13,9 kg

GATES UP TO  
 WEIGHT .....450 kg

CODE: 1710040

## MARE S 03

## SET



SPEED S .....2 pcs  
 RUN S .....1 pc  
 LAST S .....1 pc  
 PILOT SN .....2 pcs  
 FRS 2 .....1 pc  
 BOLT M10x25 .....15 pcs  
 RIVET NUT .....15 pcs

ART. SET / kg  
 MARE S 03 .....14,5 kg

GATES UP TO  
 WEIGHT .....450 kg

CODE: 1710041

## FERO SBE 02

## SET

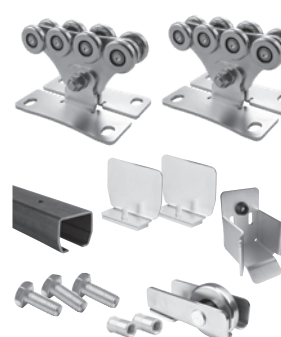

SPEED SE .....2 pcs  
 STAGE SB 5,6 .....1 pc  
 RUN S .....1 pc  
 LAST S .....1 pc  
 PILOT SN .....2 pcs  
 BOLT M10x25 .....15 pcs  
 RIVET NUT .....15 pcs

ART. SET / kg  
 FEROSBE 02 .....42,3 kg

GATES UP TO  
 WEIGHT .....325 kg  
 LENGHT .....4 m

CODE: 1710014

## FEROSBE 03

## SET



SPEED SE .....2 pcs  
 STAGE SB 5,6 .....1 pc  
 RUN S .....1 pc  
 LAST S .....1 pc  
 PILOT SN .....2 pcs  
 FRS 2 .....1 pc  
 BOLT M10x25 .....15 pcs  
 RIVET NUT .....15 pcs

ART. SET / kg  
 FEROSBE 03 .....42,9 kg

GATES UP TO  
 WEIGHT .....325 kg  
 LENGHT .....4 m

CODE: 1710044

**FERO SIZE 02****SET**

SPEED SE .....2 pcs  
 STAGE SZ 5,6 .....1 pc  
 RUN S .....1 pc  
 LAST S .....1 pc  
 PILOT SN .....2 pcs  
 BOLT M10x25 .....15 pcs  
 RIVET NUT .....15 pcs

ART. SET / kg  
 FERO SIZE 02 .....42,3 kg

GATES UP TO

WEIGHT .....325 kg  
 LENGHT .....4 m

CODE: 1710007

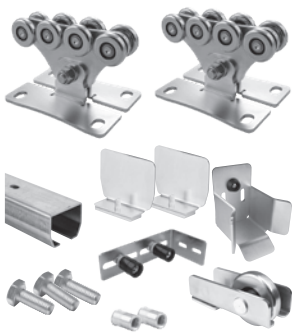
**FERO SIZE 03****SET**

SPEED SE .....2 pcs  
 STAGE SZ 5,6 .....1 pc  
 RUN S .....1 pc  
 LAST S .....1 pc  
 PILOT SN .....2 pcs  
 FRS 2 .....1 pc  
 BOLT M10x25 .....15 pcs  
 RIVET NUT .....15 pcs

ART. SET / kg  
 FERO SIZE 03 .....42,9 kg

GATES UP TO

WEIGHT .....325 kg  
 LENGHT .....4 m

CODE: 1710045

**ENZO SB 02****SET**

SPEED S .....2 pcs  
 STAGE SB 6 .....1 pc  
 RUN S .....1 pc  
 LAST S .....1 pc  
 PILOT SN .....2 pcs  
 BOLT M10x25 .....15 pcs  
 RIVET NUT .....15 pcs

ART. SET / kg  
 ENZO SB 02 .....46,9 kg

GATES UP TO

WEIGHT .....450 kg  
 LENGHT .....4,5 m

CODE: 1710012

**ENZO SB 03****SET**

SPEED S .....2 pcs  
 STAGE SB 6 .....1 pc  
 RUN S .....1 pc  
 LAST S .....1 pc  
 PILOT SN .....2 pcs  
 FRS 2 .....1 pc  
 BOLT M10x25 .....15 pcs  
 RIVET NUT .....15 pcs

ART. SET / kg  
 ENZO SB 03 .....47,5 kg

GATES UP TO

WEIGHT .....450 kg  
 LENGHT .....4,5 m

CODE: 1710051

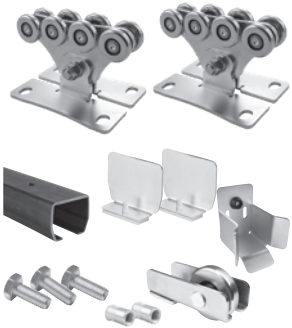
**DINO SBE 02****SET**

SPEED SE .....2 pcs  
 STAGE SB 6 .....1 pc  
 RUN S .....1 pc  
 LAST S .....1 pc  
 PILOT SN .....2 pcs  
 BOLT M10x25 .....15 pcs  
 RIVET NUT .....15 pcs

ART. SET / kg  
 DINO SBE 02 .....44,5 kg

GATES UP TO

WEIGHT .....325 kg  
 LENGHT .....4,5 m

CODE: 1710047

**DINO SBE 03****SET**

SPEED SE .....2 pcs  
 STAGE SB 6 .....1 pc  
 RUN S .....1 pc  
 LAST S .....1 pc  
 PILOT SN .....2 pcs  
 FRS 2 .....1 pc  
 BOLT M10x25 .....15 pcs  
 RIVET NUT .....15 pcs

ART. SET / kg  
 DINO SBE 03 .....45,1 kg

GATES UP TO

WEIGHT .....325 kg  
 LENGHT .....4,5 m

CODE: 1710048

**ENZO SZ 02****SET**

SPEED S .....2 pcs  
 STAGE SZ 6 .....1 pc  
 RUN S .....1 pc  
 LAST S .....1 pc  
 PILOT SN .....2 pcs  
 BOLT M10x25 .....15 pcs  
 RIVET NUT .....15 pcs

ART. SET / kg  
 ENZO SZ 02 .....46,9 kg

GATES UP TO

WEIGHT .....450 kg  
 LENGHT .....4,5 m

CODE: 1710005

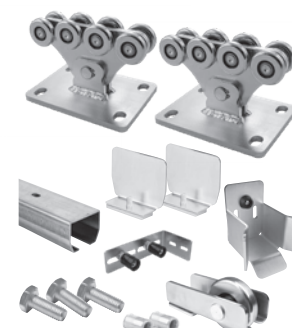
**ENZO SZ 03****SET**

SPEED S .....2 pcs  
 STAGE SZ 6 .....1 pc  
 RUN S .....1 pc  
 LAST S .....1 pc  
 PILOT SN .....2 pcs  
 FRS 2 .....1 pc  
 BOLT M10x25 .....15 pcs  
 RIVET NUT .....15 pcs

ART. SET / kg  
 ENZO SZ 03 .....47,5 kg

GATES UP TO

WEIGHT .....450 kg  
 LENGHT .....4,5 m

CODE: 1710046

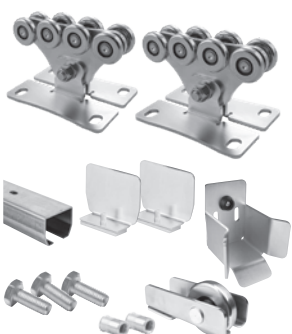
**DINO SIZE 02****SET**

SPEED SE .....2 pcs  
 STAGE SZ 6 .....1 pc  
 RUN S .....1 pc  
 LAST S .....1 pc  
 PILOT SN .....2 pcs  
 BOLT M10x25 .....15 pcs  
 RIVET NUT .....15 pcs

ART. SET / kg  
 DINO SIZE 02 .....44,5 kg

GATES UP TO

WEIGHT .....325 kg  
 LENGHT .....4,5 m

CODE: 1710049

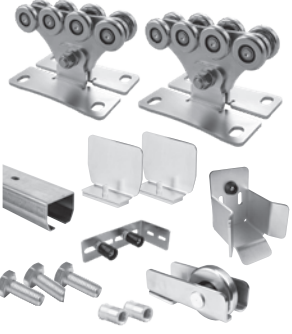
**DINO SIZE 03****SET**

SPEED SE .....2 pcs  
 STAGE SZ 6 .....1 pc  
 RUN S .....1 pc  
 LAST S .....1 pc  
 PILOT SN .....2 pcs  
 FRS 2 .....1 pc  
 BOLT M10x25 .....15 pcs  
 RIVET NUT .....15 pcs

ART. SET / kg  
 DINO SIZE 03 .....45,1 kg



















GATES UP TO

WEIGHT .....325 kg  
 LENGHT .....4,5 m

CODE: 1710050

# CAIS CANTILEVER SE

CANTILEVER SE						
	mm; kg	mm; kg	mm; kg	mm; kg	mm; kg	mm; kg
A	3000	3200	3400	3600	3800	4000
max. weight gate	325 kg	325 kg	325 kg	325 kg	325 kg	325 kg
B	900	960	1020	1080	1140	1200
C	1300	1360	1420	1480	1540	1600
D	270	270	270	270	270	270
F	130	130	130	130	130	130

-  EASY ASSEMBLING
-  C 2 HQ BEARINGS
-  FAST NO WELDING
-  CARRIAGES CENTER HOLES MILLED NOT LASERED
-  15 BOLTS 15 RIVET NUTS INCLUDED (\*)
-  MULTI RIVETED SECTIONS
-  «C» TRACK SERIAL NO. 100% COMPATIBILITY CARRIAGE TESTED
-  JAPANESE ROBOTICS FANUC
-  GERMAN STEEL WUPPERMANN
-  UNIVERSITY OF TECHNOLOGY – BRNO
-  HOT DIPPED GALVANIZED
-  - 37°C TESTED & PROVEN
-  ARROW STRAIGHT «C» TRACK
-  + 50°C TESTED & PROVEN
-  BUILD IN FLYING HOLE PUNCH – EVERY 400 mm
-  NO WELDING NEEDED
-  GALVANIZED INTERNAL EDGES
-  MADE IN CZECH REPUBLIC

$$B = 0,3 \times A$$



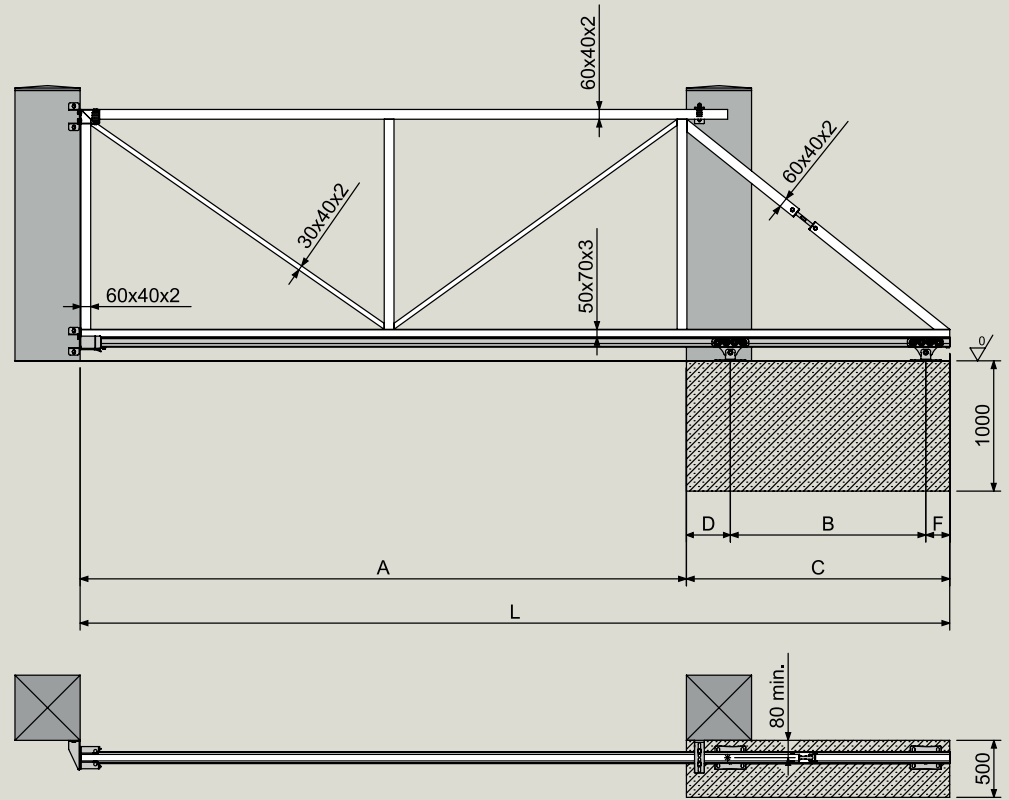
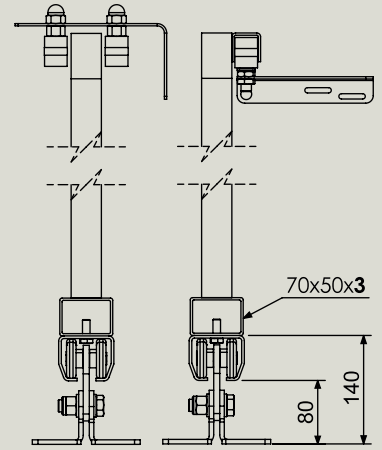















$$L = A + B + D + F$$



(\*) ONLY SETS

# CAIS CANTILEVER S

CANTILEVER S								
	mm; kg	mm; kg	mm; kg	mm; kg	mm; kg	mm; kg	mm; kg	mm; kg
A	3000	3200	3400	3600	3800	4000	4200	4500
max. weight gate	325 kg	325 kg	325 kg	350 kg	375 kg	400 kg	425 kg	450 kg
B	900	960	1020	1080	1140	1200	1260	1350
C	1440	1500	1560	1620	1680	1740	1800	1890
D	270	270	270	270	270	270	270	270

-  EASY ASSEMBLING
-  FAST NO WELDING
-  15 BOLTS  
15 RIVET NUTS INCLUDED (\*)
-  «C» TRACK SERIAL NO.  
100% COMPATIBILITY  
CARRIAGE TESTED
-  GERMAN STEEL  
WUPPERMANN
-  HOT DIPPED GALVANIZED
-  ARROW STRAIGHT  
«C» TRACK
-  BUILD IN FLYING HOLE  
PUNCH – EVERY 400 mm
-  GALVANIZED  
INTERNAL EDGES
-  MADE IN  
CZECH REPUBLIC
-  C 2  
HQ BEARINGS
-  CARRIAGES CENTER  
HOLES MILLED  
NOT LASERED
-  MULTI RIVITED  
SECTIONS
-  JAPANESE ROBOTICS  
FANUC
-  UNIVERSITY OF  
TECHNOLOGY – BRNO
-  - 37°C  
TESTED & PROVEN
-  + 50°C  
TESTED & PROVEN
-  NO WELDING  
NEEDED

$$B = 0,3 \times A$$

$$L = A + B + (2 \times D) + E$$

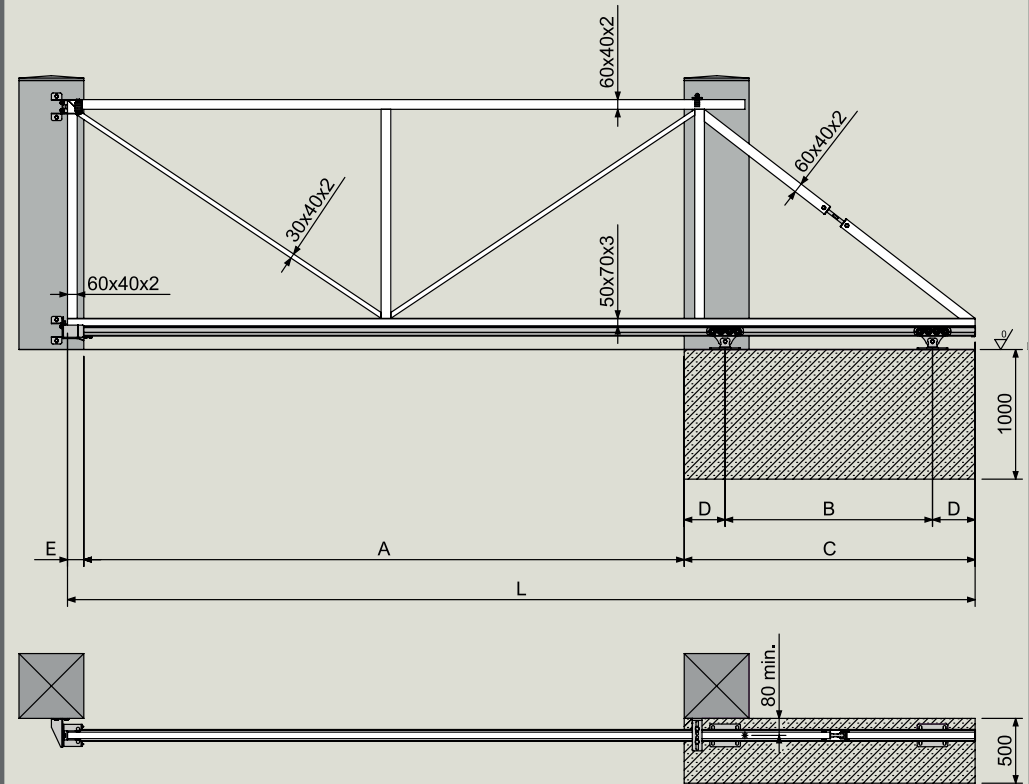
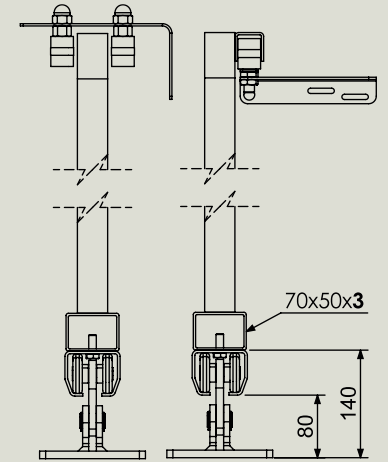

(\*) ONLY SETS

# CAIS CANTILEVER SK

CANTILEVER SK	mm; kg	mm; kg	mm; kg	mm; kg	mm; kg	mm; kg	mm; kg	mm; kg
A	3000	3200	3400	3600	3800	4000	4200	4500
max. weight gate	325 kg	325 kg	325 kg	350 kg	375 kg	400 kg	425 kg	450 kg
B	900	960	1020	1080	1140	1200	1260	1350
C	1440	1500	1560	1620	1680	1740	1800	1890
D	270	270	270	270	270	270	270	270



SUITABLE FOR INCLINED SURFACE INSTALLATION



ASYMMETRIC EIGHT WHEELED CARRIAGE



EASY ASSEMBLING



C2 HQ BEARINGS



FAST NO WELDING



CARRIAGES CENTER HOLES MILLED NOT LASERED



15 BOLTS 15 RIVET NUTS INCLUDED (\*)



MULTI RIVITED SECTIONS



«C» TRACK SERIAL NO. 100% COMPATIBILITY CARRIAGE TESTED



JAPANESE ROBOTICS FANUC



GERMAN STEEL WUPPERMANN



UNIVERSITY OF TECHNOLOGY - BRNO



HOT DIPPED GALVANIZED



-37°C TESTED & PROVEN



ARROW STRAIGHT «C» TRACK



+50°C TESTED & PROVEN



BUILD IN FLYING HOLE PUNCH - EVERY 400 mm



MADE IN CZECH REPUBLIC



GALVANIZED INTERNAL EDGES



NO WELDING NEEDED

$$B = 0,3 \times A$$



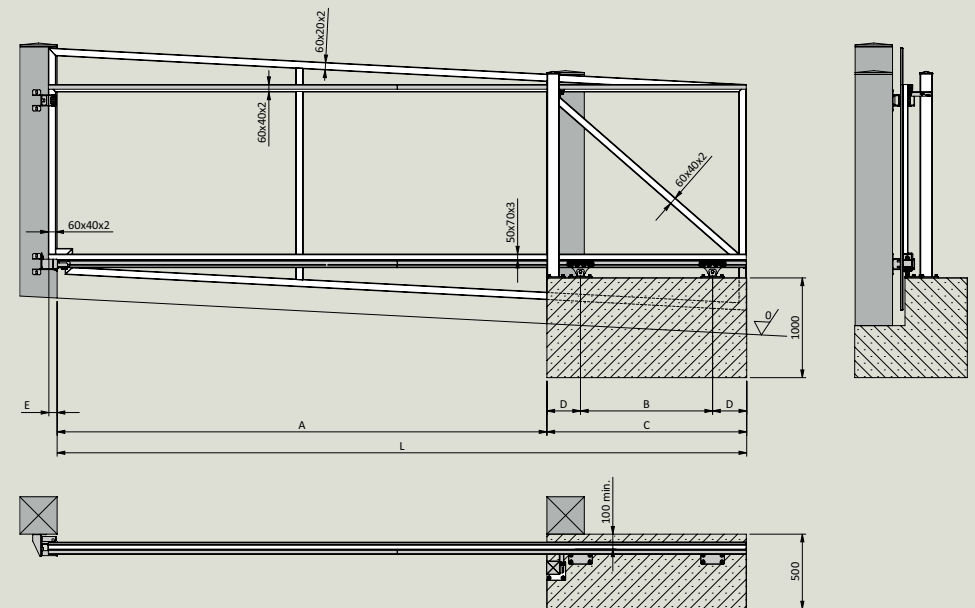
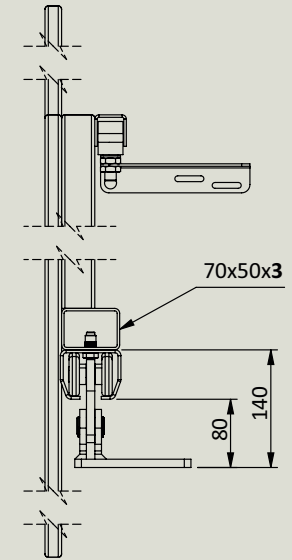

$$L = A + B + (2 \times D) + E$$

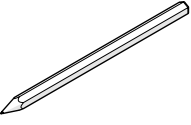
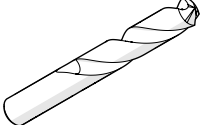
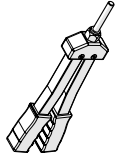
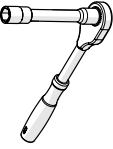

(\*) ONLY SETS

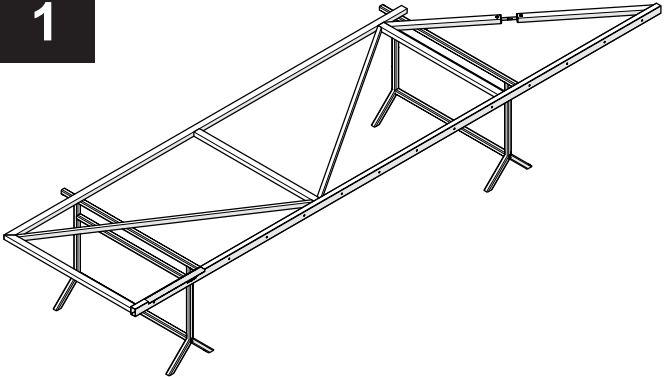
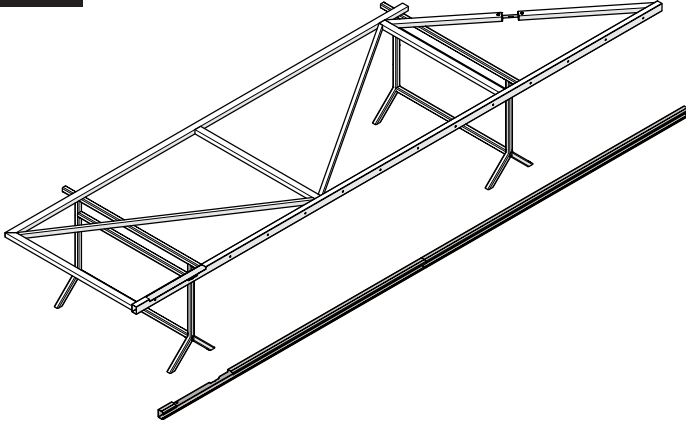
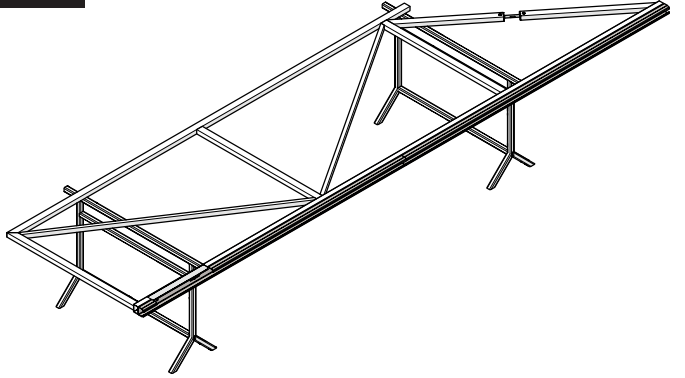
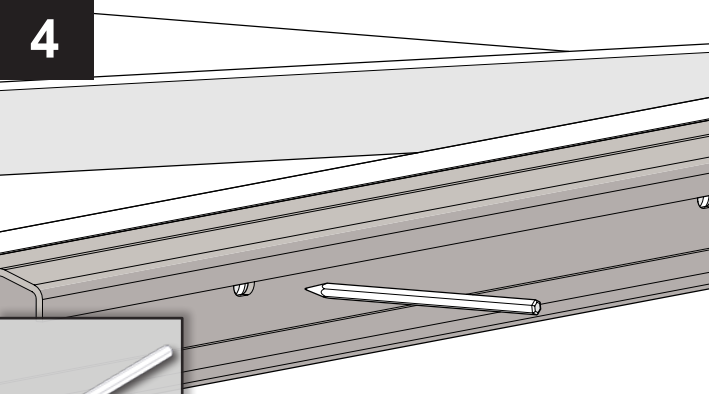
# CAIS MANUAL

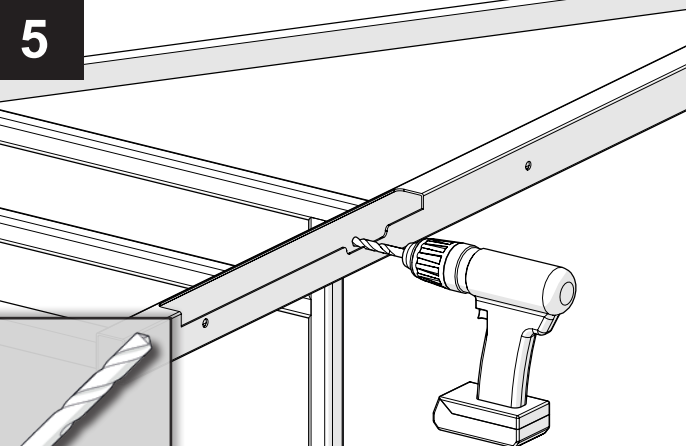
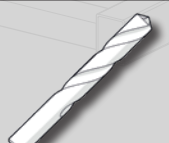
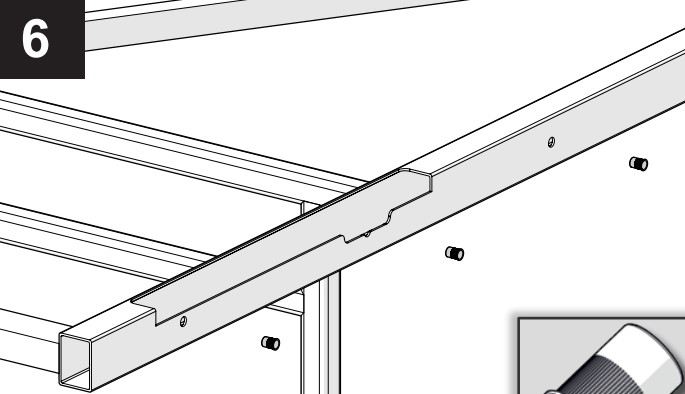
			
Pencil	Drill bit 13mm	Riveting pliers	Ratchet 17 mm

<b>1</b> 	<b>2</b> 	<b>3</b> 
<b>4</b>   PENCIL	<b>5</b>   13 m	<b>6</b>   RIVET NUT

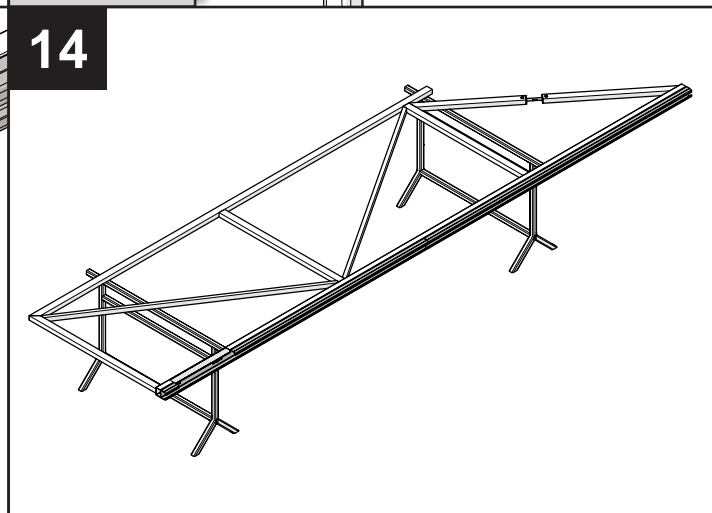
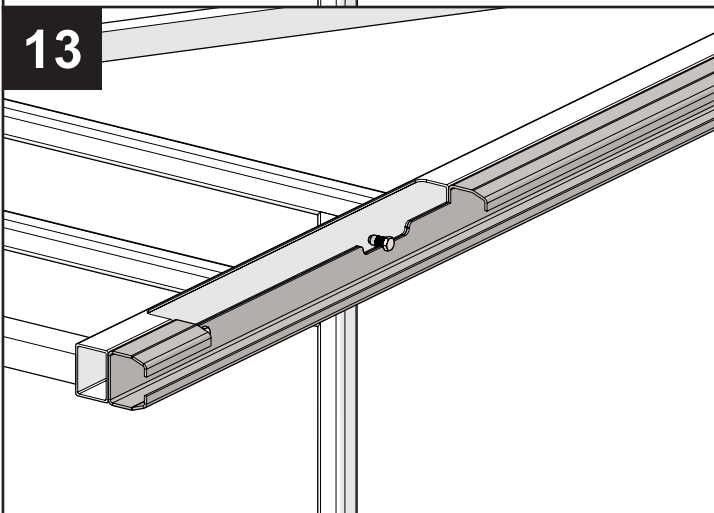
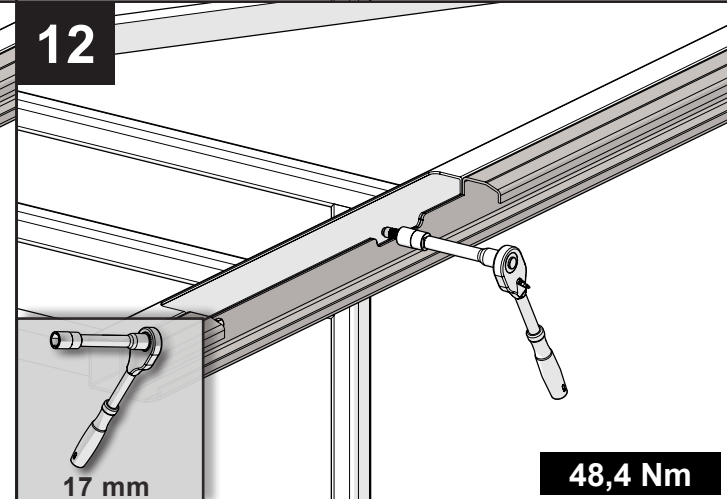
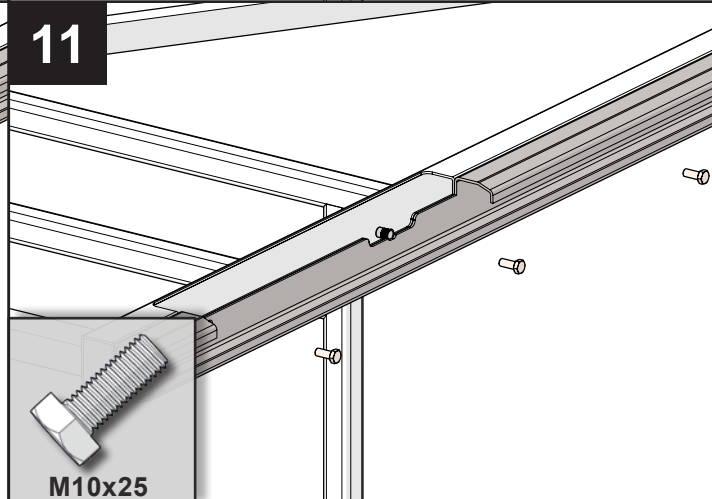
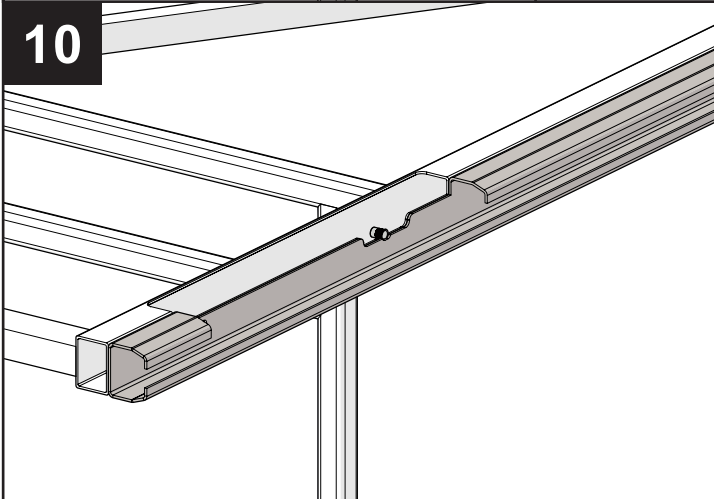
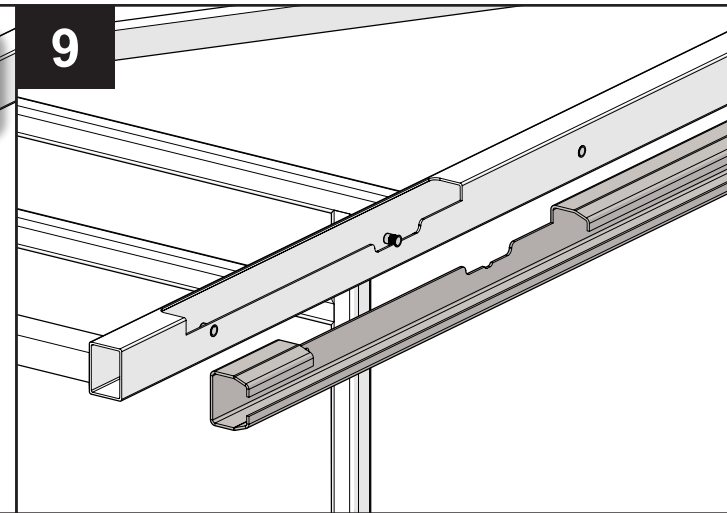
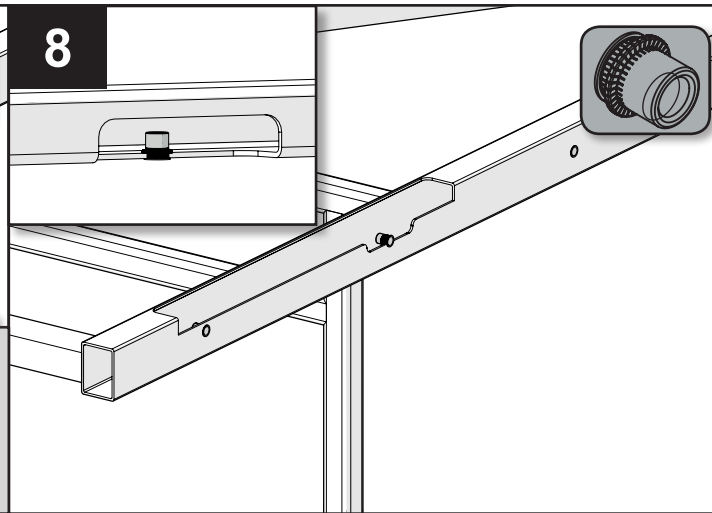
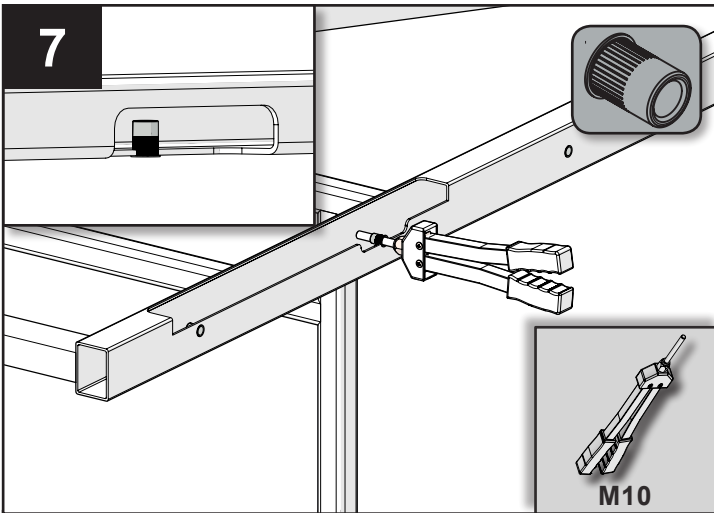



1

SPEED SE; S; SK

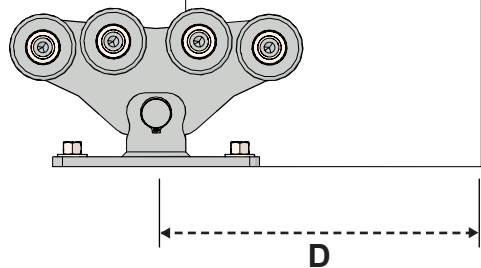

2



3



4

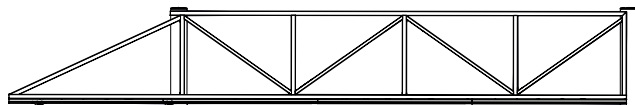

5

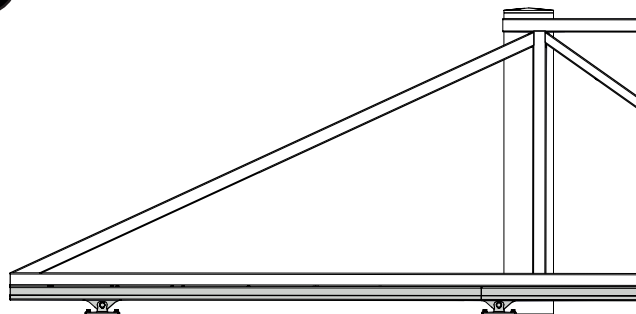

6

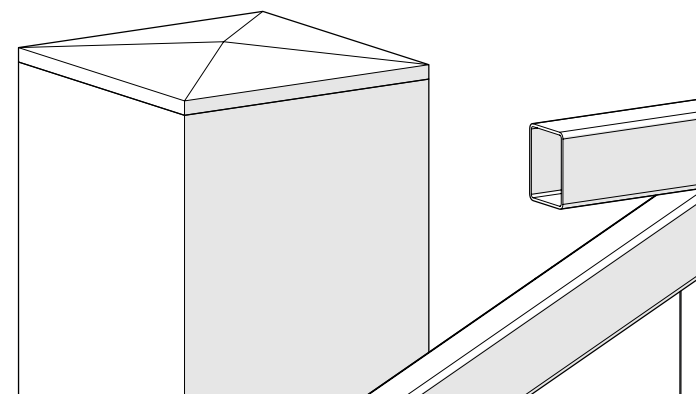

7

FRS 2

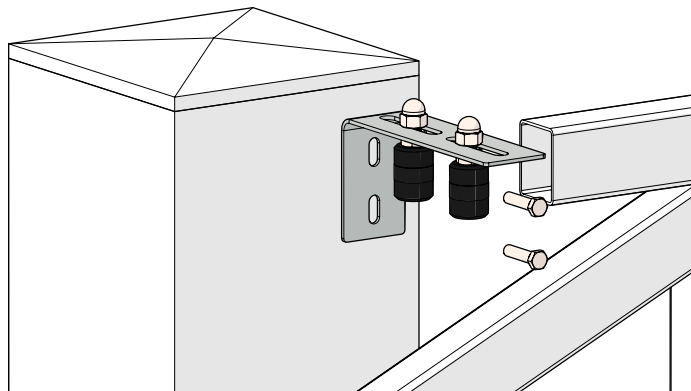

8

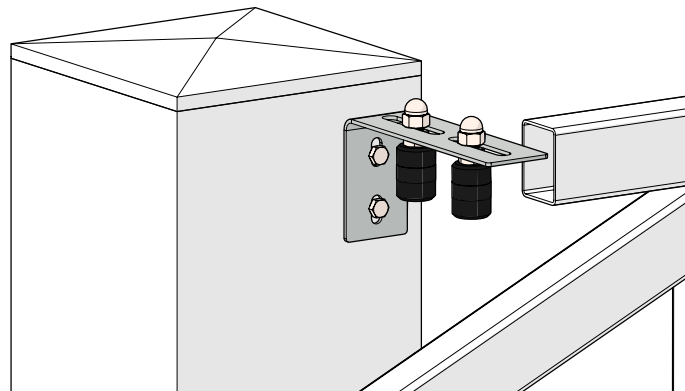

9

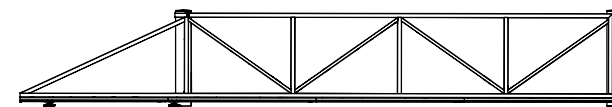

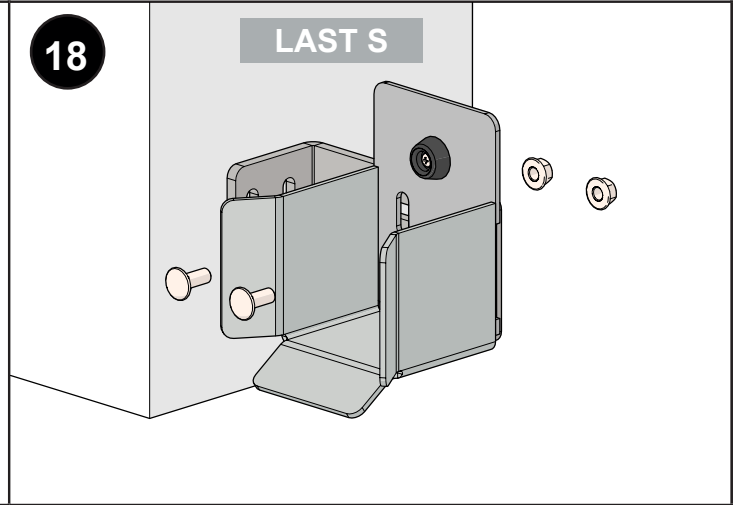
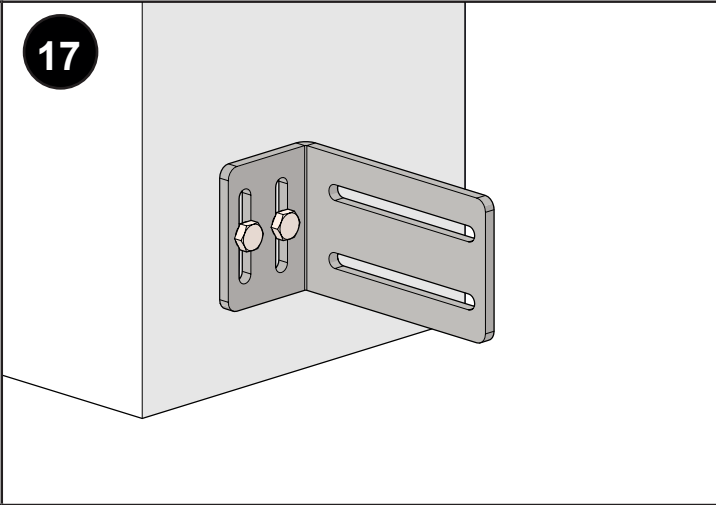
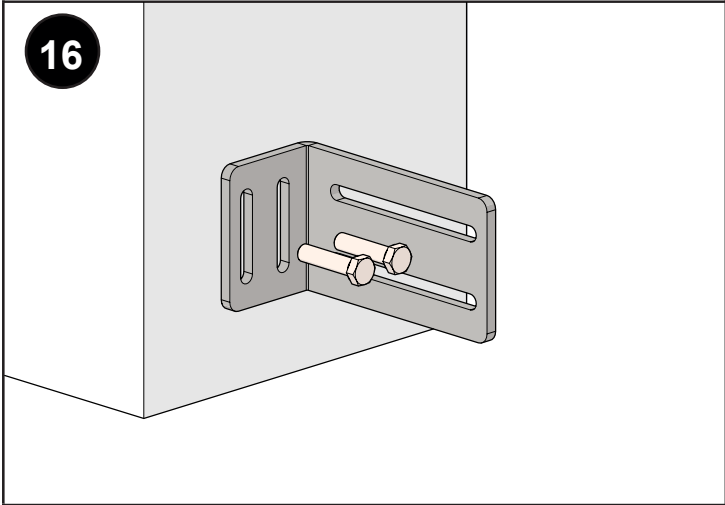
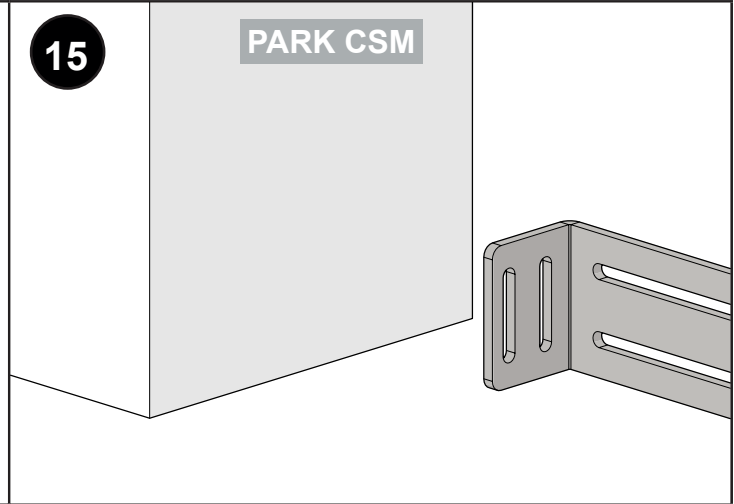
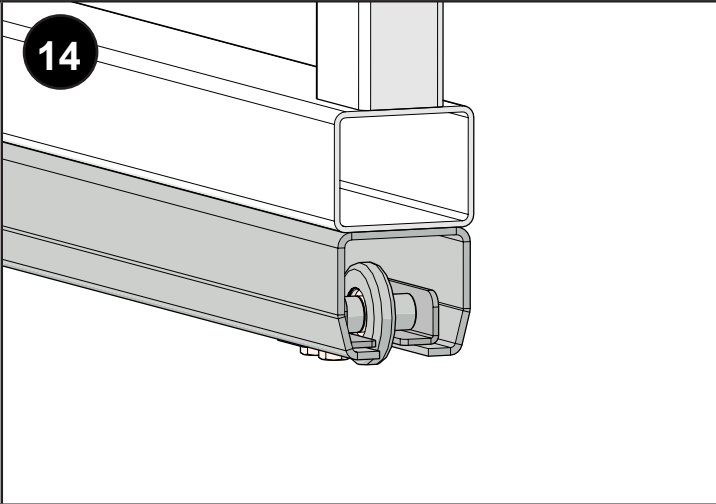
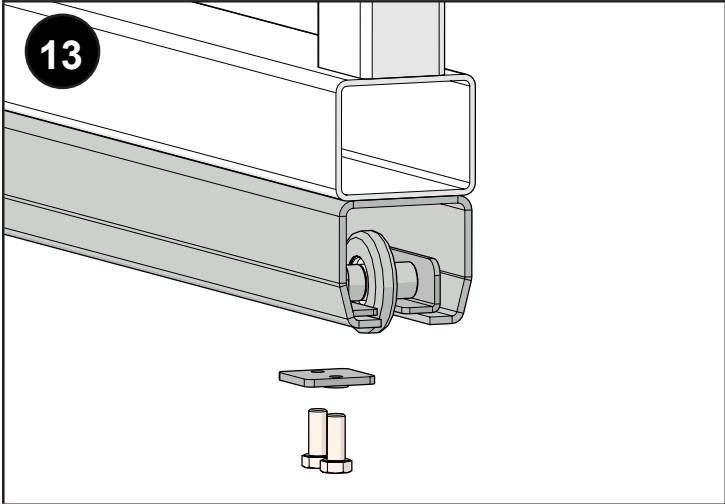
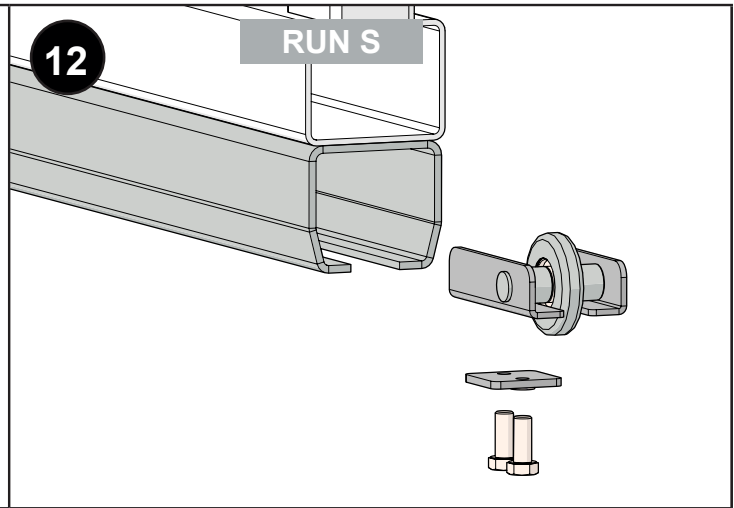
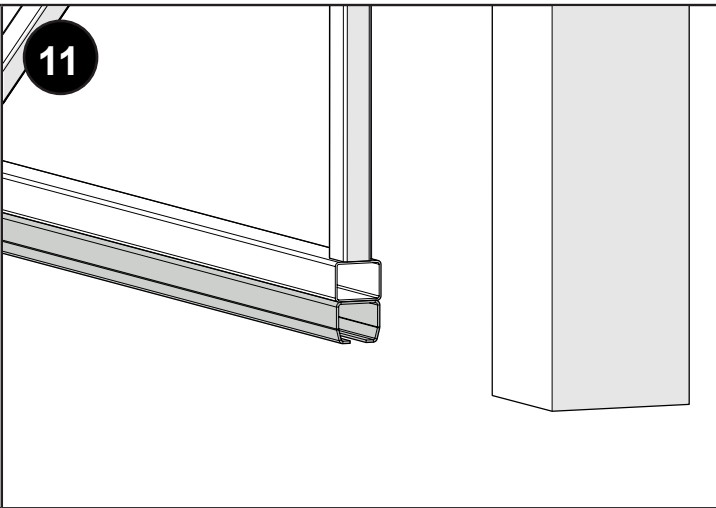
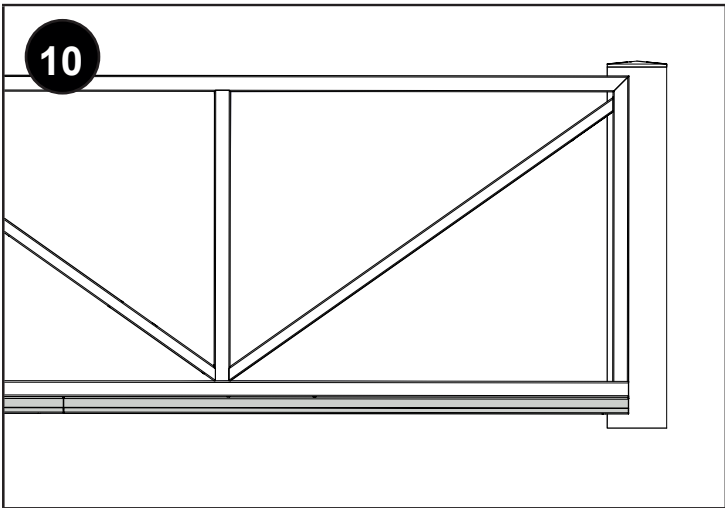

19

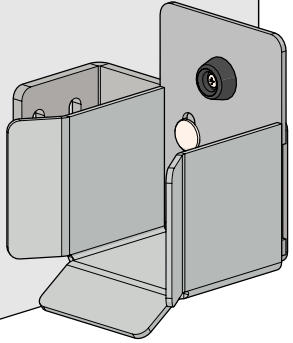

20

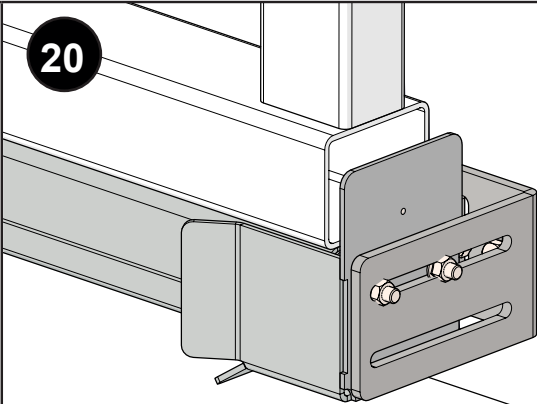

21

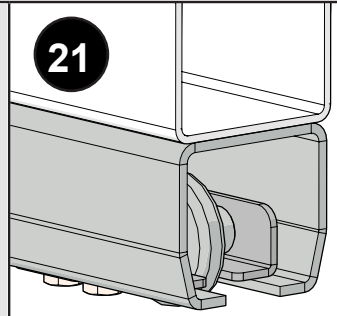

22

PILOT SN

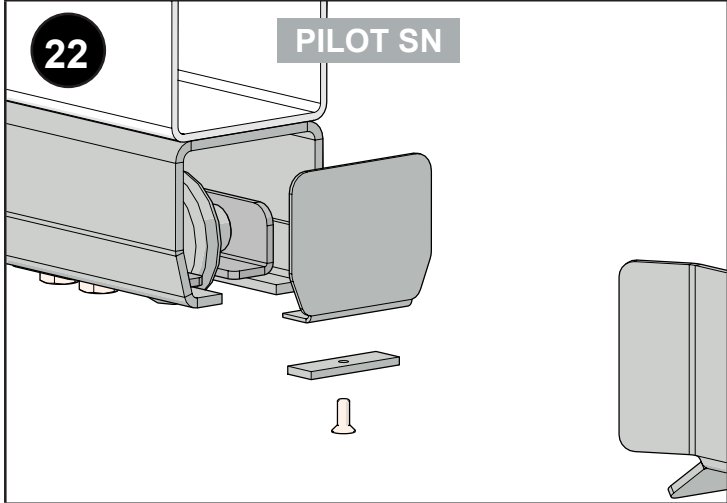

23

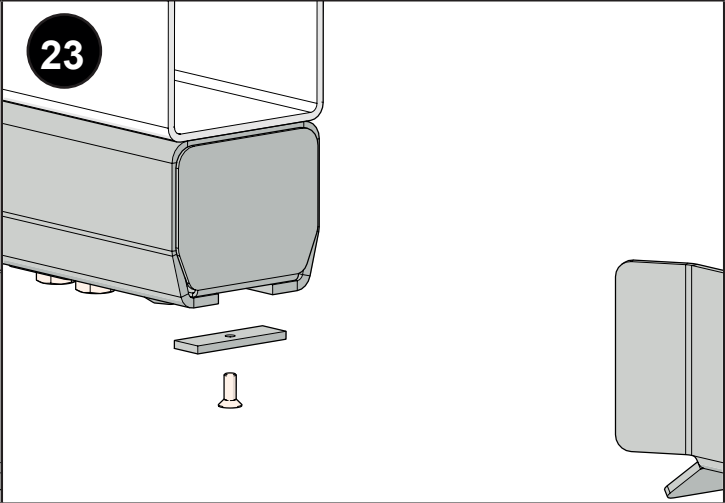

24

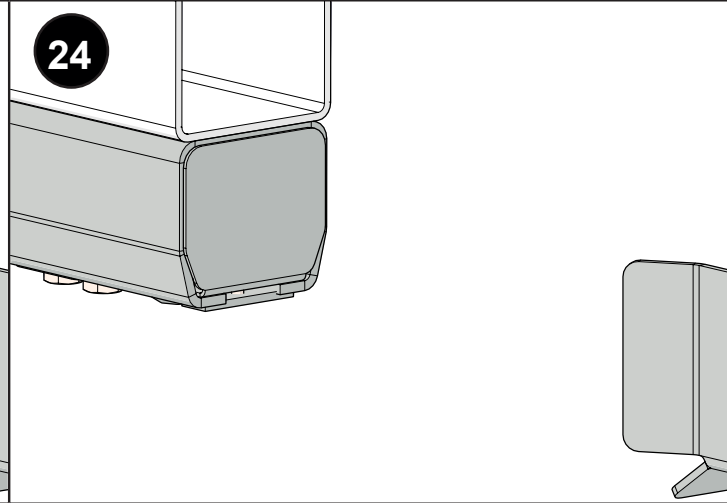

25

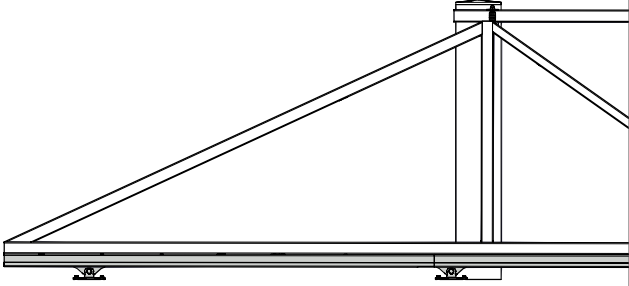

26

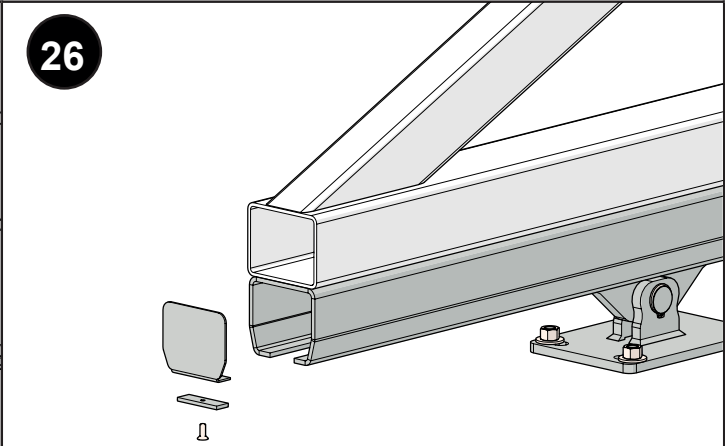

27

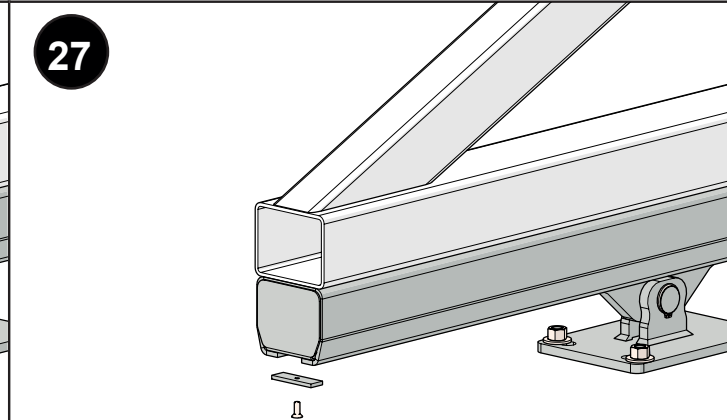

28

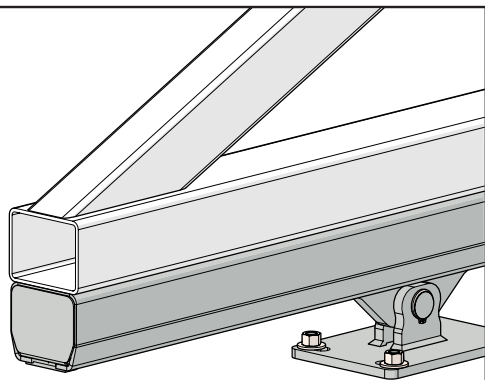

29

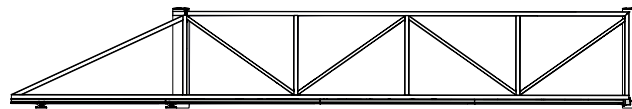

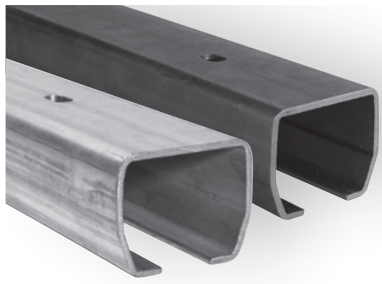

- (GB) „C“ PROFILE GUIDE FOR CANTILEVER GATE
- (D) „C“ PROFIL FÜR FREITRAGENDE SCHIEBETÖRE
- (F) GUIDE À PROFIL EN « C » POUR PORTAIL AUTOPORTANT
- (E) GUÍA CON PERFIL "C" PARA PUERTA VOLADIZA
- (P) GUIA DE PERFIL "C" PARA PORTÃO CANTILEVER
- (I) GUIDA CON PROFILO A "C" PER CANCELLO AUTOPORTANTE
- (DK) "C" PROFILVANGE TIL FRITTBÆRENDE PORT
- (NL) "C" PROFIEL GELEIDER VOOR VRIJDRAGENDE SCHUIFPOORT
- (N) "C"-PROFILSKINNE FOR FRITTBÆRENDE PORTX
- (S) "C" GEJDPROFIL FÖR FRIBÄRANDE GRIND
- (FIN) "C" -PROFILIOHJAIN ULOKEKANNETTEISEEN PORTTIIN
- (PL) SZYNA DO BRAM SAMONOŚNYCH
- (SK) NOSNÝ „C“ PROFIL PRE POSUVNÚ SAMONOSNÚ BRÁNU
- (EE) "C" -PROFILI JUHIK KONSOOLVÄRAVA JAOKS
- (LT) „C“ FORMOS PROFILIUOTAS KREIPTUVAS GEMBINIAMS VARTAMS
- (LV) "C" VEIDA PROFILS KONSOLVEIDA VĀRTIEM

- (CZ) ŠÍNA „C“ PROFIL PRO POSUVNOU SAMONOSNOU BRÁNU
- (RO) GHIDAJ CU PROFIL „C“ PENTRU POARTA AUTOPORTANTĂ ÎN CONSOLĂ
- (HR) VODILICA „C“ PROFILA ZA KLIZNA DVORIŠNA VRATA
- (RUS) НАПРАВЛЯЮЩИЙ РЕЛЬС / ПРОФИЛЬ «С» ДЛЯ ОТКАТНЫХ САМОНЕСУЩИХ ВОРОТ
- (SLO) "C" VODILO ZA SAMONOSNA DRSNA VRATA
- (TR) KONSOL BAHÇE KAPISI İÇİN "C" PROFİL KIZAĞI
- (AR) اللبوة المدعمة "C" دعامة نذلية جانبية
- (CHN) 悬臂门"C"型导轨
- (MAL) PANDU PROFIL "C" UNTUK PINTU PAGAR JULUR
- (H) C-VEZETŐSÍN TOLÓKAPUHOZ
- (IL) קורה בפרופיל "C" לשער קולונדי
- (BG) "C"-ОБРАЗНА РЕЛСА ЗА КОНЗОЛНА ВРАТА
- (KO) 캔틸레버 게이트용 "C"자형 프로필 가이드
- (SRB) VODICA „C“ PROFILA ZA SAMONOSIVU KAPIJU

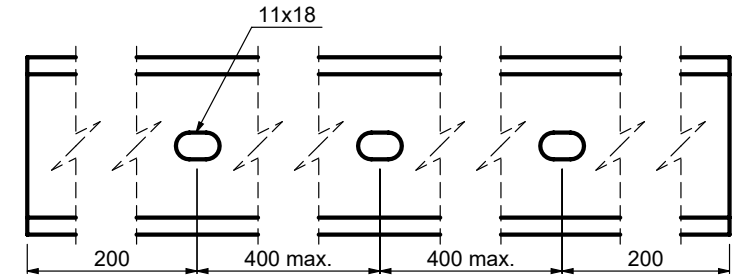
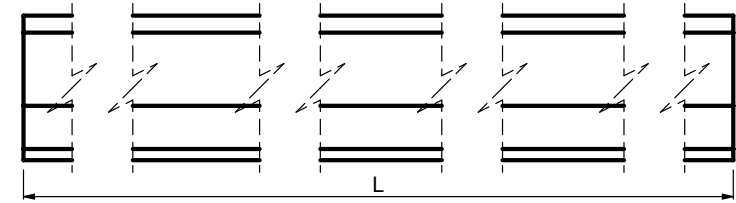
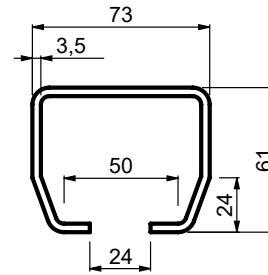
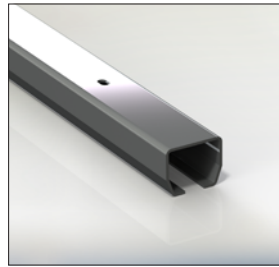
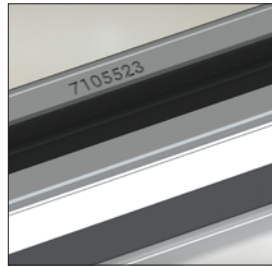
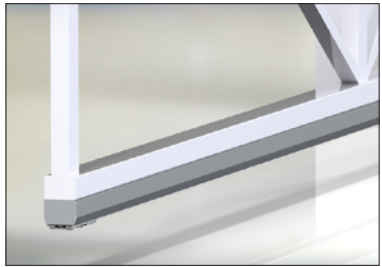

**D** **W Wuppermann**  
GERMAN STEEL

**270**  
g/m<sup>2</sup> HOT  
DIPPED  
GALVANIZED

**GALVANIZED**  
INTERNAL  
EDGES

**3,50**  
mm SPECIAL  
THICKNESS

**24**  
months 24 MONTHS  
TESTED  
& PROVEN

**-37°C**  
TESTED  
& PROVEN

**+50°C**  
TESTED  
& PROVEN

**CZ** MADE IN  
CZECH  
REPUBLIC

**BUILD IN**  
FLYING HOLE PUNCH  
EVERY 400 mm

**15 BOLTS**  
15 RIVET NUTS  
INCLUDED (\* )

**EASY**  
ASSEMBLING

**FAST**  
NO WELDING

**R&D** **BRNO**  
UNIVERSITY  
OF TECHNOLOGY

**ARROW**  
STRAIGHT  
«C» TRACK

**18** EIGHTEEN ROLL FORMERS  
THE MOST IN THE INDUSTRY  
REMOVE THE INSET «MEMORY» OF STEEL





**SLOW ROLLING**  
NO HEAT DURING THE PRODUCTION  
KEEPING THE MATERIAL WHERE IT IS ROLLED

**AVAILABLE**  
CUSTOMISED LENGTHS  
UNDER SPECIAL TERMS

**SERIAL NUMBER**  
CARRIAGE COMPATIBILITY  
TESTED & PROVEN

Art.	CARRIAGE	GUIDE	L/1pc	1pc	pcs		CODE
			mm	kg	pcs	kg	
<b>STAGE SB 6</b>	SPEED S/SE/SK	UNGALVANIZED	6000	33	24	792	1700002
<b>STAGE SB 5,6</b>	SPEED S/SE/SK	UNGALVANIZED	5600	30,8	24	739,2	1700176
<b>STAGE SB 3</b>	SPEED S/SE/SK	UNGALVANIZED	3000	16,5	24	396	1700167
<b>STAGE SB 2,8</b>	SPEED S/SE/SK	UNGALVANIZED	2800	15,4	24	369,6	1720006
<b>STAGE SB 1</b>	SPEED S/SE/SK	UNGALVANIZED	1000	5,5	24	132	1720008
<b>STAGE SZ 6</b>	SPEED S/SE/SK	GALVANIZED	6000	33	24	792	1700003
<b>STAGE SZ 5,6</b>	SPEED S/SE/SK	GALVANIZED	5600	30,8	24	739,2	1700177
<b>STAGE SZ 3</b>	SPEED S/SE/SK	GALVANIZED	3000	16,5	24	396	1700168
<b>STAGE SZ 2,8</b>	SPEED S/SE/SK	GALVANIZED	2800	15,4	24	369,6	1720016
<b>STAGE SZ 1</b>	SPEED S/SE/SK	GALVANIZED	1000	5,5	24	132	1720018



-  C 2 HQ BEARINGS
-  CARRIAGES CENTER HOLES MILLED NOT LASERED
-  MULTI RIVETED SECTIONS
-  **mono block** MONO BLOCK EIGHT WHEELED CARRIAGE
-  NO WELDED PARTS

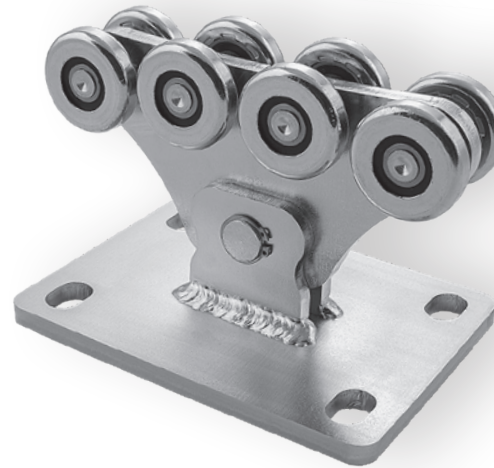

-  C 2 HQ BEARINGS
-  CARRIAGES CENTER HOLES MILLED NOT LASERED
-  MULTI RIVETED SECTIONS
-  **mono block** MONO BLOCK EIGHT WHEELED CARRIAGE

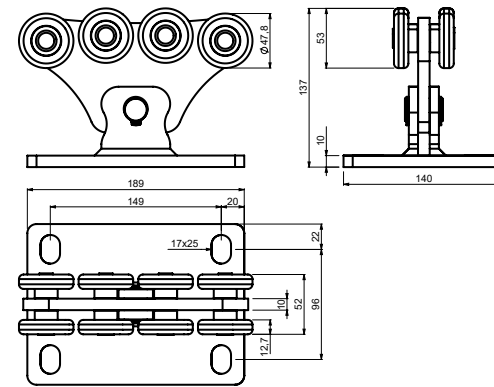
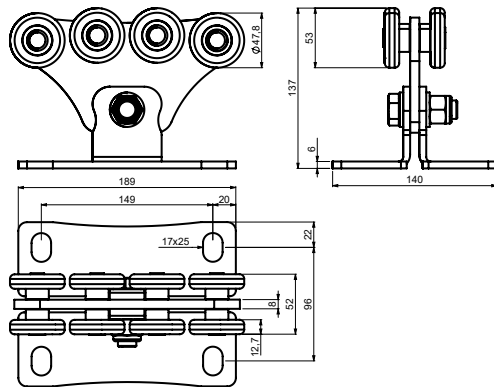

- (GB) EIGHT WHEELED CARRIAGE FOR CANTILEVER GATE
- (D) ROLLAPPARAT MIT ACHT ROLLEN FÜR FREITRAGENDE SCHIEBETORE
- (F) CHARIOT À HUIT ROUES POUR PORTAIL AUTOPORTANT
- (E) CARRIL DE OCHO RUEDAS PARA PUERTA VOLADIZA
- (P) CORREIÇA DE OITO ROLDANAS PARA PORTÃO CANTILEVER
- (I) CARRELLO A OTTO RUOTE PER CANCELLO AUTOPORTANTE
- (DK) OTTE TRANSPORTHJUL TIL FRITTBÆRENDE PORT
- (NL) ACHTVOUDIG WIELENBLOK VOOR VRIJDRAGENDE SCHUIFPOORT
- (N) ÅTTEHJULS DRIVSKINNE TIL FRITTBÆRENDE PORT
- (S) ÅTTAHJULIG VAGN FÖR FRIBÄRENDE GRIND
- (FIN) KAHDEKSAN PYÖRÄN ALUSTA ULOKEKANNETTEISEEN PORTTIIN
- (PL) WÓZEK 8-ROLKOWY DO BRAM SAMONOSNYCH
- (SK) VOZÍK OSEMKOLIEČKOVÝ PRE POSUVNÚ SAMONOSNÚ BRÁNU
- (EE) KAHESARATTALINE SUPORT KONSOOLVÁRAVA JAOKS
- (LT) VEŽIMĖLIS GEMBINIAMS VARTAMS SU AŠTUONIAIS RATUKAIS
- (LV) ASTOŅU RUĻĻU BLOKS KONSOLVEIDA VĀRTIEM

- (CZ) VOZÍK OSMIKOLOVÝ PRO POSUVNOU SAMONOSNOU BRÁNU
- (RO) CĂRUCIOR PE OPT ROTI PENTRU POARTA AUTOPORTANTĂ ÎN CONSOLĂ
- (HR) NOSAČ S OSAM KOTAČA ZA KLIZNA DVORIŠNA VRATA
- (RUS) ВОСЬМИКОЛЕСНАЯ РОЛИКОВАЯ ТЕЛЕЖКА ДЛЯ ОТКАТНЫХ САМОНЕСУЩИХ ВОРОТ
- (SLO) VOZIČEK Z OSMIMI KOLESI ZA SAMONOSNA DRSNA VRATA
- (TR) KONSOL BAHÇE KAPISI İÇİN SEKİZ TEKERLEKLİ TAŞIYICI
- (AR) عربة مزودة بثمانى عجلات للوابات المدعسة
- (CHN) 悬臂门八轮滑架
- (MAL) PENYORONG LAPAN RODA UNTUK PINTU PAGAR JULUR
- (H) NYOLCGÖRGÖS FUTÓKOCSI TOLÓKAPUHOZ
- (IL) קרונית שמנונה גלגלים לשער קונדולי
- (BG) КОЛИЧКА С ОСЕМ РОЛКИ ЗА КОНЗОЛНА ВРАТА
- (KO) 8개 휠이 있는 캔틸레버 게이트용 이송대
- (SRB) NOSAČ SA OSAM TOČKIČA ZA SAMONOSIVU KAPIJU





- (GB) EIGHT WHEELED CARRIAGE FOR CANTILEVER GATE
- (D) ROLLAPPARAT MIT ACHT ROLLEN FÜR FREITRAGENDE SCHIEBETORE
- (F) CHARIOT À HUIT ROUES POUR PORTAIL AUTOPORTANT
- (E) CARRIL DE OCHO RUEDAS PARA PUERTA VOLADIZA
- (P) CORREIÇA DE OITO ROLDANAS PARA PORTÃO CANTILEVER
- (I) CARRELLO A OTTO RUOTE PER CANCELLO AUTOPORTANTE
- (DK) OTTE TRANSPORTHJUL TIL FRITTBÆRENDE PORT
- (NL) ACHTVOUDIG WIELENBLOK VOOR VRIJDRAGENDE SCHUIFPOORT
- (N) ÅTTEHJULS DRIVSKINNE TIL FRITTBÆRENDE PORT
- (S) ÅTTAHJULIG VAGN FÖR FRIBÄRENDE GRIND
- (FIN) KAHDEKSAN PYÖRÄN ALUSTA ULOKEKANNETTEISEEN PORTTIIN
- (PL) WÓZEK 8-ROLKOWY DO BRAM SAMONOSNYCH
- (SK) VOZÍK OSEMKOLIEČKOVÝ PRE POSUVNÚ SAMONOSNÚ BRÁNU
- (EE) KAHESARATTALINE SUPORT KONSOOLVÁRAVA JAOKS
- (LT) VEŽIMĖLIS GEMBINIAMS VARTAMS SU AŠTUONIAIS RATUKAIS
- (LV) ASTOŅU RUĻĻU BLOKS KONSOLVEIDA VĀRTIEM

- (CZ) VOZÍK OSMIKOLOVÝ PRO POSUVNOU SAMONOSNOU BRÁNU
- (RO) CĂRUCIOR PE OPT ROTI PENTRU POARTA AUTOPORTANTĂ ÎN CONSOLĂ
- (HR) NOSAČ S OSAM KOTAČA ZA KLIZNA DVORIŠNA VRATA
- (RUS) ВОСЬМИКОЛЕСНАЯ РОЛИКОВАЯ ТЕЛЕЖКА ДЛЯ ОТКАТНЫХ САМОНЕСУЩИХ ВОРОТ
- (SLO) VOZIČEK Z OSMIMI KOLESI ZA SAMONOSNA DRSNA VRATA
- (TR) KONSOL BAHÇE KAPISI İÇİN SEKİZ TEKERLEKLİ TAŞIYICI
- (AR) عربة مزودة بثمانى عجلات للوابات المدعسة
- (CHN) 悬臂门八轮滑架
- (MAL) PENYORONG LAPAN RODA UNTUK PINTU PAGAR JULUR
- (H) NYOLCGÖRGÖS FUTÓKOCSI TOLÓKAPUHOZ
- (IL) קרונית שמנונה גלגלים לשער קונדולי
- (BG) КОЛИЧКА С ОСЕМ РОЛКИ ЗА КОНЗОЛНА ВРАТА
- (KO) 8개 휠이 있는 캔틸레버 게이트용 이송대
- (SRB) NOSAČ SA OSAM TOČKIČA ZA SAMONOSIVU KAPIJU

Art.	A	GUIDE	1pc	Image		CODE
	max. mm			kg	pcs	
<b>SPEED SE</b>	4000	STAGE SB/SZ	3,5	2	7	1700174

Art.	A	GUIDE	1pc	Image		CODE
	max. mm			kg	pcs	
<b>SPEED S</b>	4500	STAGE SB/SZ	4,7	2	9,4	1700001



-  SUITABLE FOR INCLINED SURFACE INSTALLATION
-  ASYMMETRIC EIGHT WHEELED CARRIAGE
-  C 2 HQ BEARINGS
- mono block** MONO BLOCK EIGHT WHEELED CARRIAGE
-  CARRIAGES CENTER HOLES MILLED NOT LASERED
-  MULTI RIVETED SECTIONS

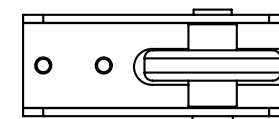
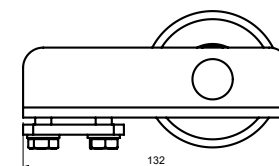
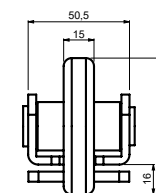
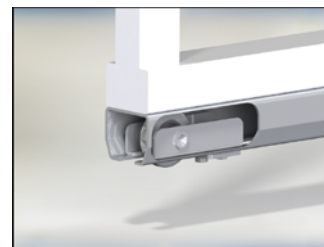
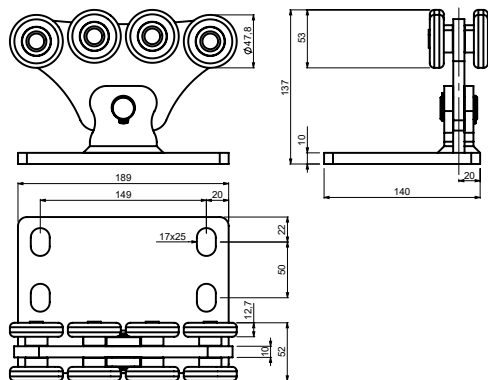
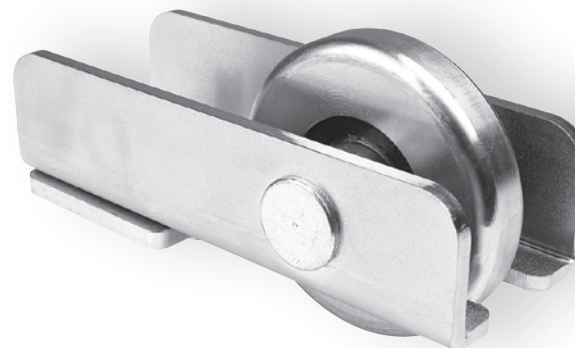



- (GB) EIGHT WHEELED CARRIAGE FOR CANTILEVER GATE
- (D) ROLLAPPARAT MIT ACHT ROLLEN FÜR FREITRAGENDE SCHIEBETORE
- (F) CHARIOT À HUIT ROUES POUR PORTAIL AUTOPORTANT
- (E) CARRIL DE OCHO RUEDAS PARA PUERTA VOLADIZA
- (P) CORREDIÇA DE OITO ROLDANAS PARA PORTÃO CANTILEVER
- (I) CARRELLO A OTTO RUOTE PER CANCELLO AUTOPORTANTE
- (DK) OTTE TRANSPORTHJUL TIL FRITBÆRENDE PORT
- (NL) ACHTVOUDIG WIELENBLOK VOOR VRIJDRAGENDE SCHUIFPOORT
- (N) ÅTTEHJULS DRIVSKINNE TIL FRITTBÆRENDE PORT
- (S) ÅTTA HJULIG VAGN FÖR FRIBÄRANDE GRIND
- (FIN) KAHDEKSAN PYÖRÄN ALUSTA ULOKEKANNETTEISEEN PORTTIIN
- (PL) WÓZEK 8-ROLKOWY DO BRAM SAMONOŚNYCH
- (SK) VOZÍK OSEM KOLIEČKOVÝ PRE POSUVNÚ SAMONOSNÚ BRÁNU
- (EE) KAHESARATTA LINE SUPORT KONSOOLVÄRAVA JAOKS
- (LT) VEŽIMĖLIS GEMBINIAMS VARTAMS SU AŠTUONIAIS RATUKAIS
- (LV) ASTOŅU RULĻU BLOKS KONSOLVEIDA VĀRTIEM

- (CZ) VOZÍK OSMIKOLOVÝ PRO POSUVNOU SAMONOSNOU BRÁNU
- (RO) CĂRUCIOR PE OPT ROȚI PENTRU POARTA AUTOPORTANTĂ ÎN CONSOLĂ
- (HR) NOSAČ S OSAM KOTAČA ZA KLIZNA DVORIŠNA VRATA
- (RUS) ВОСЬМИКОЛЕСНАЯ РОЛИКОВАЯ ТЕЛЕЖКА ДЛЯ ОТКАТНЫХ САМОНЕСУЩИХ ВОРОТ
- (SLO) VOZIČEK Z OSMIMI KOLESI ZA SAMONOSNA DRSNA VRATA
- (TR) KONSOL BAHÇE KAPISI İÇİN SEKİZ TEKERLEKLİ TAŞIYICI
- (AR) عربة مزودة بثمانى عجلات للوابت المدعمة
- (CHN) 悬臂门八轮滑架
- (MAL) PENYORONG LAPAN RODA UNTUK PINTU PAGAR JULUR
- (H) NYOLCGÖRGŐS FUTÓKOCSI TOLÓKAPUHOZ
- (IL) קרונית משמנה גלגלים לשער קנדולרי
- (BG) КОЛИЧКА С ОСЕМ РОЛКИ ЗА КОНЗОЛНА ВРАТА
- (KO) 8개 휠이 있는 캔틸레버 게이트용 이동대
- (SRB) NOSAČ SA OSAM TOČKIČKA ZA SAMONOSIVU KAPIJU

- (GB) GUIDE SUPPORT WHEEL FOR CANTILEVER GATE
- (D) STÜTZRAD FÜR FREITRAGENDE SCHIEBETORE
- (F) ROUE DE SUPPORT DE GUIDE POUR PORTAIL AUTOPORTANT
- (E) RUEDA CON SOPORTE DE GUÍA PARA PUERTA VOLADIZA
- (P) ROLDANA DE SUPORTE GUIA PARA PORTÃO CANTILEVER
- (I) RUOTA DI SOSTEGNO DELLA GUIDA PER CANCELLO AUTOPORTANTE
- (DK) VANGESTØTTEHJUL TIL FRITBÆRENDE PORT
- (NL) DRAAGWIEL VOOR GELEIDING VRIJDRAGENDE SCHUIFPOORT
- (N) STYRESKINNE FOR STØTTEHJUL TIL FRITTBÆRENDE PORT
- (S) STÖDHJUL FÖR FRIBÄRANDE GRIND
- (FIN) OHJAIMEN TUKIPYÖRÄ ULOKEKANNETTEISEEN PORTTIIN
- (PL) ROLKA NAJAZDOWA DO BRAM SAMONOŚNYCH
- (IL) גלגל תומך לשיער קנדולרי
- (BG) НАБЕШ С КЛАДКОУ ПРЕ ПОСУВНУ САМОНОСНУ БРАНУ
- (EE) JUHI TUGIRATAS KONSOOLVÄRAVA JAOKS
- (LT) KREIPTUVO ATRAMOS RATUKAS GEMBINIAMS VARTAMS
- (LV) VADOTNES BALSTA RULLĻTIS KONSOLVEIDA VĀRTIEM

- (CZ) NÁBĚH S KLADKOU PRO POSUVNOU SAMONOSNOU BRÁNU
- (RO) ROATĂ DE SUSȚINERE GHIDAJ PENTRU POARTA AUTOPORTANTĂ ÎN CONSOLĂ
- (HR) NOSIVI KOTAČ VODILICE ZA KLIZNA DVORIŠNA VRATA
- (RUS) КОНЦЕВОЙ РОЛИК ДЛЯ ОТКАТНЫХ САМОНЕСУЩИХ ВОРОТ
- (SLO) PODPORNO KOLO VODILA ZA SAMONOSNA DRSNA VRATA
- (TR) KONSOL BAHÇE KAPISI İÇİN KIZAK DESTEK TEKERLEĞİ
- (AR) عجلة دعامة ديدالية للوابت المدعمة
- (CHN) 悬臂门导轨支轮
- (MAL) RODA SOKONGAN PANDU UNTUK PINTU PAGAR JULUR
- (H) VEZETŐ, MEGTÁMASZTÓ GÖRGŐ TOLÓKAPUHOZ
- (IL) גלגל תומך לשיער קנדולרי
- (BG) РОЛКА ЗА РЕЛСА ЗА КОНЗОЛНА ВРАТА
- (KO) 캔틸레버 게이트용 가이드 지지 휠
- (SRB) NOSEĆI TOČKIČ VODICE ZA SAMONOSIVU KAPIJU

Art.	A	GUIDE	1pc			CODE
	max. mm			kg	pcs	
<b>SPEED SK</b>	4500	STAGE SB/SZ	4,7	2	9,4	1700189

Art.	GUIDE	1pc			CODE
			kg	pcs	
<b>RUN S</b>	STAGE SB/SZ	0,97	10	9,7	1700004

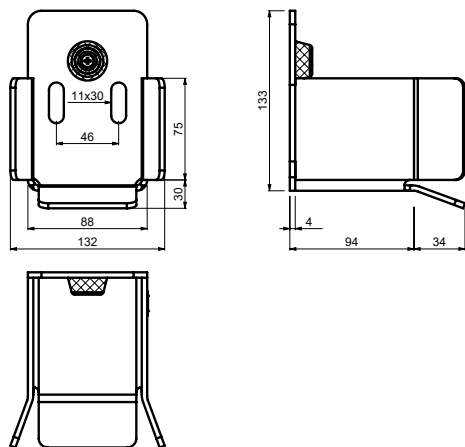
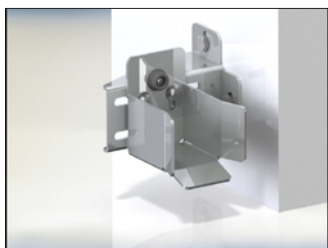

- (GB) END STOP FOR CANTILEVER GATE
- (D) EINLAUFSCHUH FÜR FREITRAGENDE SCHIEBETORE
- (F) BUTÉE POUR PORTAIL AUTOPORTANT
- (E) TOPE FINAL PARA PUERTA VOLADIZA
- (P) BATENTE PARA PORTÃO CANTILEVER
- (I) FERMO DI FINE CORSA PER CANCELLO AUTOPORTANTE
- (DK) ENDESTOP TIL FRITBÆRENDE PORT
- (NL) EINDSTOP VOOR VRIJDRAGENDE SCHUIFPOOR
- (N) ENDESTOPPER FOR FRITTBÆRENDE PORT
- (S) ÄNDSTOPP FÖR FRIBÄRANDE GRIND
- (FIN) PÄÄTYPYSÄYTIN ULKOKÄNNETTEISEEN PORTTIIN
- (PL) ODBOJNIK DO BRAM SAMONOŚNYCH
- (SK) DOJAZDOVÁ KAPSA SPODNÁ PRE POSUVNÚ SAMONOSNÚ BRÁNU
- (EE) OTSALÕPP KONSOLVÄRAVA JAOKS
- (LT) GALINIS RIBOKLIS GEMBINIAMS VARTAMS
- (LV) GALA AIZTURIS KONSOLVEIDA VÄRTIEM

- (CZ) DOJEZDOVÁ KAPSA SPODNÍ PRO POSUVNOU SAMONOSNOU BRÁNU
- (RO) OPRITOR CURSĂ PENTRU POARTA AUTOPORTANTĂ ÎN CONSOLĂ
- (HR) GRANIČNIK ZA KLIZNA DVORIŠNA VRATA
- (RUS) УЛАВЛИВАТЕЛЬ НИЖНИЙ ДЛЯ ОТКАТНЫХ САМОНЕСУЩИХ ВОРОТ
- (SLO) ZAUSTAVLJALNIK ZA SAMONOSNA DRŠNA VRATA
- (TR) KONSOL BAĖÇE KAPISI İÇİN UÇ TESPİT PARÇASI
- (AR) المدع الطرفي للبوابة المدعومة
- (CHN) 悬臂门终点挡块
- (MAL) PENYENDAL HUJUNG UNTUK PINTU PAGAR JULUR
- (H) ÜTKÖZŐ TOLÓKAPUHOZ
- (IL) מקביל קצה לשער קונזולי
- (BG) СТОПЕР ЗА КОНЗОЛНА ВРАТА
- (KO) 캔틸레버 게이트용 종단 정지대
- (SRB) GRANIČNIK ZA SAMONOSIVU KAPIJU

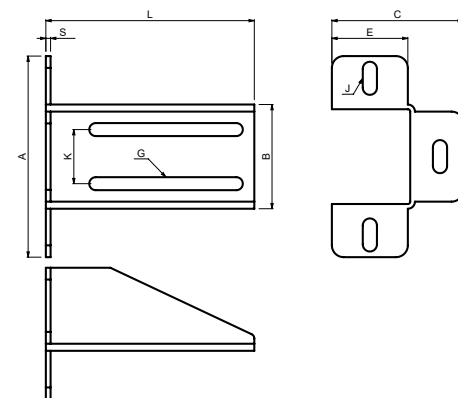
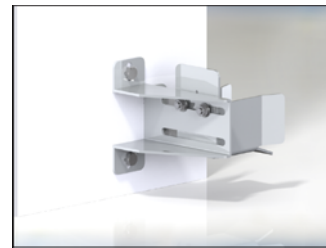
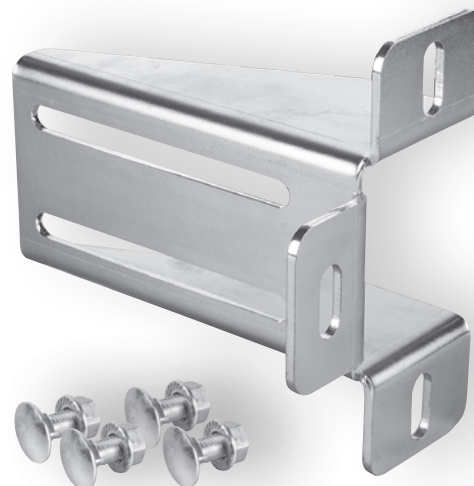

- (GB) END STOP BRACKET
- (D) KONSOLE FÜR EINLAUFSCHUH
- (F) ÉTRIER POUR BUTÉE
- (E) SOPORTE DE TOPE FINAL
- (P) SUPORTE DE BATENTE
- (I) STAFFA PER FERMO DI FINE CORSA
- (DK) ENDESTOP BESLAG
- (NL) EINDSTOP BEVESTIGINGSBEUGEL
- (N) STOPPEBRACKET
- (S) ÄNDSTOPP KONSOL
- (FIN) PÄÄTYPYSÄYTIMEN KANNATIN
- (PL) WSPORNIK ODBOJNIKA
- (SK) KONZOLA PRE DOJAZDOVÚ KAPSU
- (EE) OTSALÕPU KLAMBER
- (LT) GALINIO RIBOKLIO GEMBĖ
- (LV) GALA AIZTURA KRONŠTEINS

- (CZ) KONZOLA PRO DOJEZDOVOU KAPSU
- (RO) OPRITOR CURSĂ CONSOLĂ
- (HR) KONZOLA GRANIČNIKA
- (RUS) КРОНШТЕЙН УЛАВЛИВАТЕЛЯ
- (SLO) OPORNIK ZAUSTAVLJALNIKA
- (TR) UÇ TESPİT PARÇASI DIRSEĞİ
- (AR) سنادة المدع الطرفي
- (CHN) 终点挡块支座
- (MAL) PENDAKAP PENYENDAL HUJUNG
- (H) ÜTKÖZŐ-KERET
- (IL) תופסן למקביל קצה
- (BG) СКОБА ЗА СТОПЕР
- (KO) 종단 정지대 브래킷
- (SRB) KONZOLA GRANIČNIKA

Art.	GUIDE	1pc			CODE
		kg	pcs	kg	
<b>LAST S</b>	STAGE SB/SZ	1,24	2	2,48	1700005

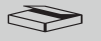
Art.	L	A	B	C	E	G	J	K	S	END STOP	1pc			CODE
											kg	pcs	kg	
mm														
<b>PARK</b>	175	170	88	95	50	11X132	12X30	46	4	LAST/PADDOCK	1,11	2	2,22	1700006
<b>PARK 240</b>	245	170	88	95	50	11X200	12X30	46	4	LAST/PADDOCK	1,35	2	2,7	1700196



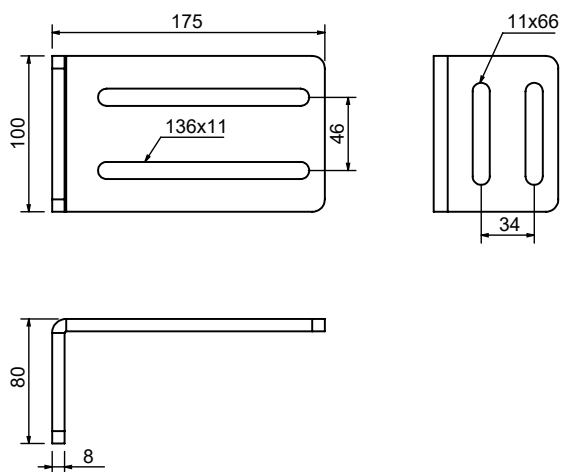
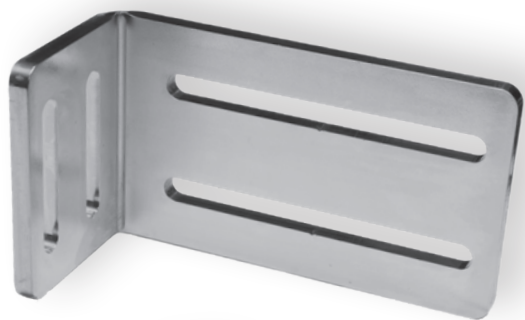

- (GB) END STOP BRACKET
- (D) KONSOLE FÜR EINLAUFSCHUH
- (F) ÉTRIER POUR BUTÉE
- (E) SOPORTE DE TOPE FINAL
- (P) SUPORTE DE BATENTE
- (I) STAFFA PER FERMO DI FINE CORSA
- (DK) ENDESTOP BESLAG
- (NL) EINDSTOP BEVESTIGINGSBEUGEL
- (N) STOPPEBRAKETT
- (S) ÄNDSTOPP KONSOL
- (FIN) PÄÄTYPYSÄYTTIMEN KANNATIN
- (PL) WSPORNIK ODBOJNIKA
- (SK) KONZOLA PRE DOJAZDOVÚ KAPSU
- (EE) OTSALÕPU KLAMBER
- (LT) GALINIO RIBOKLIO GEMBĖ
- (LV) GALA AIZTURA KRONŠTEINS

- (CZ) KONZOLA PRO DOJEZDOVOU KAPSU
- (RO) OPRITOR CURSĂ CONSOLĂ
- (HR) KONZOLA GRANIČNIKA
- (RUS) КРОНШТЕЙН УЛАВЛИВАТЕЛЯ
- (SLO) OPORNIK ZAUSTAVLJALNIKA
- (TR) UÇ TESPİT PARÇASI DİRSEĞİ
- (AR) منقطة التوقف الطارفي
- (CHN) 终点挡块支座
- (MAL) PENDAKAP PENYENDAL HUJUNG
- (H) ÚTKÖZŐ-KERET
- (IL) מקביל קצה
- (BG) СКОБА ЗА СТОПЕР
- (KO) 종단 정지대 브라켓
- (SRB) KONZOLA GRANIČNIKA

Art.	BRACKET	1pc		CODE
		kg	pcs	
<b>PARK CSM</b>	LAST/PADDOCK	1,36	2	1700359

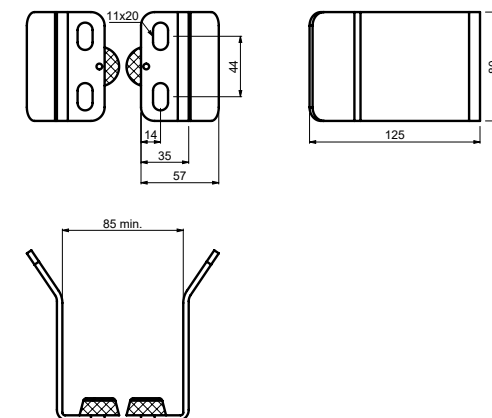
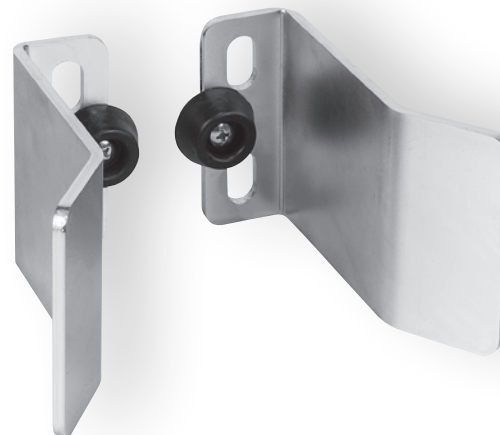

- (GB) END STOP
- (D) ENDANSCHLAG
- (F) BUTÉE
- (E) TOPE FINAL
- (P) FIM DE CORSO
- (I) ARRESTO TERMINALE
- (DK) ENDESTOP
- (NL) EINDSTOP
- (N) ENDESTOPP
- (S) ÄNDSTOPP
- (FIN) RAJOITIN
- (PL) ZDERZAK KRĄNCOWY
- (SK) DORAZ
- (EE) OTSA LÕPPR
- (LT) GALINIS RIBOKLIS
- (LV) GALA AIZTURIS

- (CZ) KONCOVÝ DORAZ
- (RO) OPRITOR FINAL
- (HR) GRANIČNIK
- (RUS) КОНЦЕВОЙ УПОР
- (SLO) KONČNI ELEMENT
- (TR) UÇ TIPASI
- (AR) نقطة التوقف
- (CHN) 限位挡块
- (MAL) ADANG HUJUNG
- (H) VÉGÜTKÖZŐ
- (IL) מקביל קצה
- (BG) СТОПЕР
- (KO) 종단 정지대
- (SRB) GRANIČNIK

Art.	BRACKET	1pc		CODE
		kg	pcs	
<b>PADDOCK SM</b>	PARK/PARK 240/ PARK CSM	0,78	2	1700194

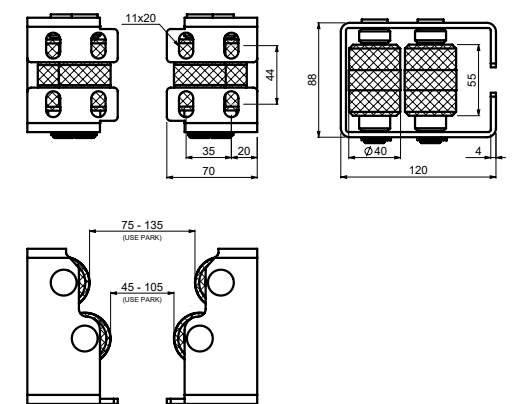
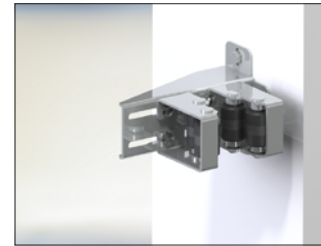
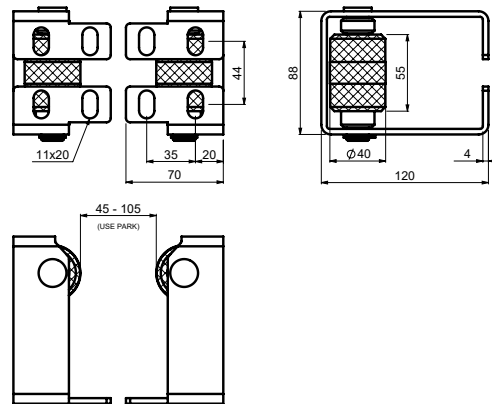
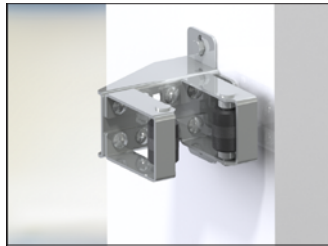
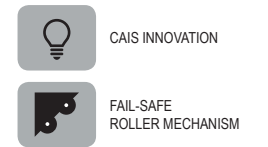
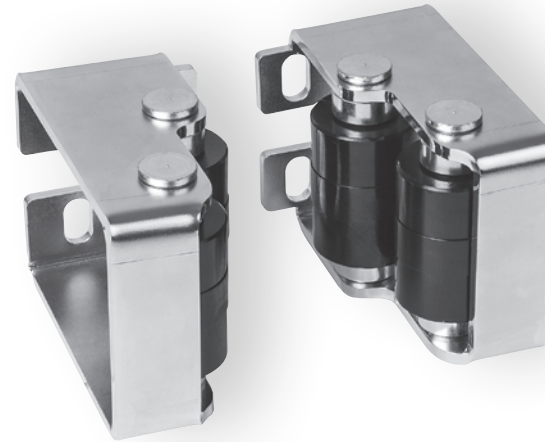
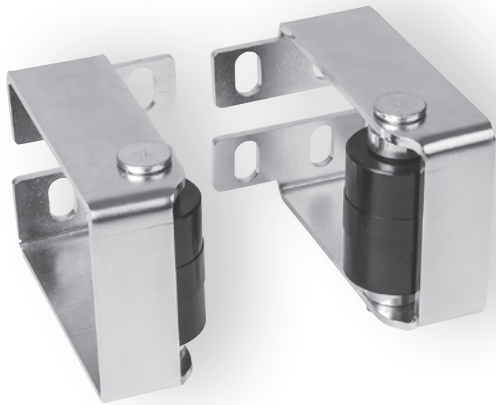



- (GB) END STOP WITH ROLLER
- (D) ENDANSCHLAG MIT ROLLE
- (F) BUTÉE AVEC ROULEAU
- (E) TOPE FINAL CON RODILLO
- (P) FIM DE CURSO COM ROLO
- (I) ARRESTO TERMINALE CON RULLO
- (DK) ENDESTOP MED VALSE
- (NL) EINDSTOP MET ROLLEN
- (N) ENDESTOPP MED RULLE
- (S) ÄNDSTOPP MED RULLE
- (FIN) RAJOITIN RULLALLA
- (PL) ZDERZAK KRAŃCOWY Z ROLKĄ
- (SK) DORAZ S VALČEKOM
- (EE) OTSALÕPP RULLIKUGA
- (LT) GALINIS RIBOKLIS SU RITINĖLIU
- (LV) GALA AIZTURIS AR RULLĪTI

- (CZ) KONCOVÝ DORAZ S KLADKOU
- (RO) OPRITOR FINAL CU ROLĂ
- (HR) GRANIČNIK S VALJKOM
- (RUS) КОНЦЕВОЙ УПОР С РОЛИКОМ
- (SLO) KONČNI ELEMENT S KOLESCEM
- (TR) MAKARALI UÇ TIPASI
- (AR) نقطة التوقف المزودة بكره
- (CHN) 帶繩子的限位擋塊
- (MAL) ADANG HUJUNG DENGAN PENGGELEK
- (H) VÉGÜTKÖZŐ GÖRGŐVEL
- (IL) מקבל מתחונן עם גלגלי אוקולין
- (BG) СТОПЕР С РОЛКА
- (KO) 롤러가 있는 종단 정지대
- (SRB) GRANIČNIK SA VALJKOM

- (GB) END STOP WITH ROLLER
- (D) ENDANSCHLAG MIT ROLLE
- (F) BUTÉE AVEC ROULEAU
- (E) TOPE FINAL CON RODILLO
- (P) FIM DE CURSO COM ROLO
- (I) ARRESTO TERMINALE CON RULLO
- (DK) ENDESTOP MED VALSE
- (NL) EINDSTOP MET ROLLEN
- (N) ENDESTOPP MED RULLE
- (S) ÄNDSTOPP MED RULLE
- (FIN) RAJOITIN RULLALLA
- (PL) ZDERZAK KRAŃCOWY Z ROLKĄ
- (SK) DORAZ S VALČEKOM
- (EE) OTSALÕPP RULLIKUGA
- (LT) GALINIS RIBOKLIS SU RITINĖLIU
- (LV) GALA AIZTURIS AR RULLĪTI

- (CZ) KONCOVÝ DORAZ S KLADKOU
- (RO) OPRITOR FINAL CU ROLĂ
- (HR) GRANIČNIK S VALJKOM
- (RUS) КОНЦЕВОЙ УПОР С РОЛИКОМ
- (SLO) KONČNI ELEMENT S KOLESCEM
- (TR) MAKARALI UÇ TIPASI
- (AR) نقطة التوقف المزودة بكره
- (CHN) 帶繩子的限位擋塊
- (MAL) ADANG HUJUNG DENGAN PENGGELEK
- (H) VÉGÜTKÖZŐ GÖRGŐVEL
- (IL) מקבל מתחונן עם גלגלי אוקולין
- (BG) СТОПЕР С РОЛКА
- (KO) 롤러가 있는 종단 정지대
- (SRB) GRANIČNIK SA VALJKOM

Art.	BRACKET	1pc			CODE
		kg	pcs	kg	
<b>PADDOCK 2</b>	PARK/PARK 240/ PARK CSM	1,4	2	2,8	1700182

Art.	BRACKET	1pc			CODE
		kg	pc	kg	
<b>PADDOCK 4</b>	PARK/PARK 240/ PARK CSM	2,1	1	2,1	1700191

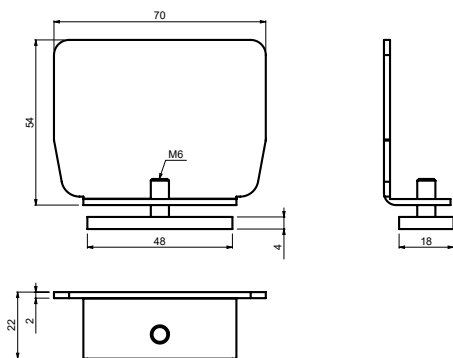
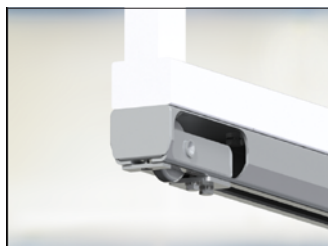

- (GB) GUIDE END CAP WITH SCREW, INDEPENDENT
- (D) ABSCHLUSSKAPPE FÜR „C“ PROFIL AUS STAHL MIT SCHRAUBE
- (F) CACHE D'EMBOÛT DE GUIDE AVEC VIS, INDÉPENDANT
- (E) TOPE FINAL DE GUÍA CON TUERCA, INDEPENDIENTE
- (P) TAMPA FINAL GUIA COM PARAFUSO, INDEPENDENTE
- (I) COPERTURA TERMINALE DELLA GUIDA CON VITE, INDIPENDENTE
- (DK) VANGEENDEHÆTTE MED SKRUE, UAFHÆNGIG
- (NL) GELEIDER EINDKAP MET SCHROEF, ONAFHANKELIJK
- (N) ENDEBESLAG FOR SKINNE MED SKRUE, UAVHENGIG
- (S) GEJD SKYDDSKÅPA MED SKRUV, OBEROENDE
- (FIN) OHJAIMEN PÄÄN RUUVILLINEN KANSI, ERILLINEN
- (PL) ZAŚLEPKA KOŃCOWA SZYNY ZE ŚRUBĄ, NIEZALEŻNA
- (SK) ZÁSLEPKA PRE NOSNÝ „C“ PROFIL, NEZÁVISLÁ SO SKRUTKOU
- (EE) JUHIKU OTSAKORK KRUUVIGA, ERALDI
- (LT) GALINIS KREIPTUVO DANGTELIS SU SRIEGIUS, ATSKIRAS
- (LV) VADOTNES GALA VĀKS AR SKRŪVI, NEATKARIĢS

- (CZ) ZÁSLEPKA PRO ŠINU „C“ PROFIL, NEZÁVISLÁ SE ŠROUBEM
- (RO) OPRITOR CURSĂ ACOPERIRE GHIDAJ CU FILET, INDEPENDENT
- (HR) ČEP VODILICE S VIJKOM, NEOVISAN
- (RUS) ЗАГЛУШКА НАПРАВЛЯЮЩЕГО РЕЛЬСА «С», НЕЗАВИСИМАЯ, С ВИНТОМ
- (SLO) ZAKLJUČNI POKROV VODILA Z VIJAKOM, NEODVISEN
- (TR) VİDALI KIZAK UÇ LASTIĞI, BAĞIMSIZ
- (AR) غطاء طرفي دليلي مع برغي، مستقل
- (CHN) 导轨独立式螺钉紧固端盖
- (MAL) PENUTUP Hujung Pandu Dengan Skru, Bebas
- (H) VEZETŐSÍN LEZÁRÓ-ELEM CSAVARRAL, FÜGGETLEN
- (IL) מכסה קצה קורה קדומילית עם בורג, עצמאי
- (BG) КРАЙНА КАПАЧКА ЗА РЕЛСА С ВИНТ, САМОСТОЯТЕЛНА
- (KO) 나사가 있는 가이드 종단 캡, 독립식
- (SRB) ČEP VOĐICE SA ZAVRTNJEM, NEZAVISAN

Art.	GUIDE	1pc			CODE
		kg	pcs	kg	
PILOT SN	STAGE SB/SZ	0,1	10	1	1700007



CZECH  
R&D



GERMAN  
STEEL



JAPANESE  
ROBOTICS



PRODUCT  
DEVELOPMENT  
PROCESS



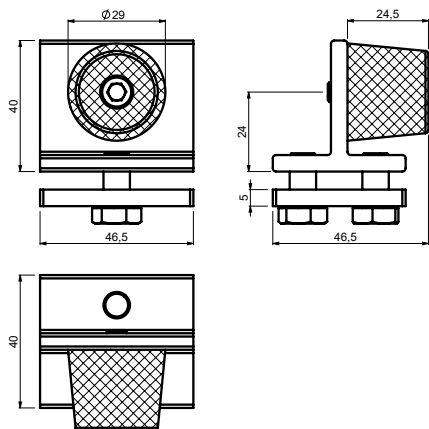
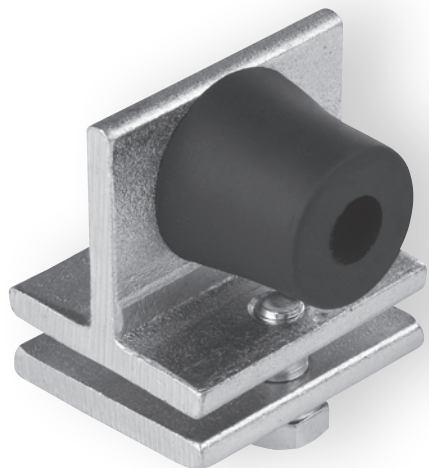

- (GB) INTERNAL GUIDE END STOP
- (D) INNENANSCHLAG FÜR „C“ PROFIL
- (F) BUTÉE INTERNE POUR GUIDE
- (E) TOPE FINAL DE GUÍA INTERNA
- (P) BATENTE GUIA INTERNA
- (I) FERMO DI FINE CORSA DELLA GUIDA INTERNA
- (DK) INTERN VANGEENDESTOP
- (NL) INTERNE GELEIDER EINDSTOP
- (N) ENDESTOPPER TIL INNVENDIG SKINNE
- (S) INTERNT GEJDÄNDSTOPP
- (FIN) SISÄINEN OHJAIMEN PÄÄN PYSÄYTIN
- (PL) WEWNĘTRZNY ODBOJNIK SZYNY
- (SK) DORAZ VNÚTORNÝ PRE NOSNÝ „C“ PROFIL
- (EE) SISEJUHIKU OTSALÕPP
- (LT) VIDINIO KREIPTUVO GALINIS RIBOKLIS
- (LV) IEKŠĒJĀIS VADOTNES GALA AIZTURIS

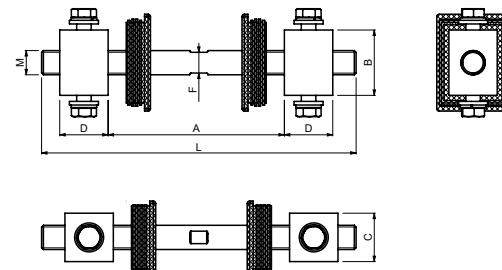
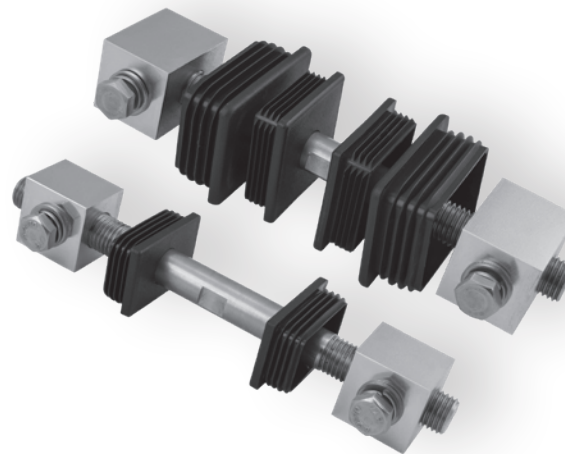

- (CZ) DORAZ VNITŘNÍ PRO ŠÍNU „C“ PROFIL
- (RO) GHIDAJ CAPĂT FINAL INTERN
- (HR) UNUTARNJI GRANIČNIK VODILICE
- (RUS) ВНУТРЕННИЙ ОГРАНИЧИТЕЛЬ НАПРАВЛЯЮЩЕГО РЕЛЬСА «С»
- (SLO) ZAUSTAVLJALNIK NOTRANJEGA VODILA
- (TR) DAHLİL KIZAK UÇ TESPİT PARÇASI
- (AR) ممانع طرفي داخلي
- (CHN) 内导轨终点挡块
- (MAL) PENYENDAL HUIJUNG PANDU DALAM
- (H) VEZETŐSÍN BELSŐ ÜTKÖZŐ
- (IL) מעצור פנימי גומי לקוורא
- (BG) ВЪТРЕШЕН СТОПЕР ЗА РЕЛСА
- (KO) 내부 가이드 종단 정지대
- (SRB) UNUTRAŠNJI GRANIČNIK VODICE

Art.	GUIDE	1pc			CODE
		kg	pcs	kg	
<b>FINISH S</b>	STAGE SB/SZ	0,23	20	4,6	1700008



- (GB) ADJUSTABLE TENSION BAR FOR CANTILEVER GATE
- (D) EINSTELLBARE ZUGSTANGE FÜR AUSLEGERTOR
- (F) BARRE DE TENSION RÉGLABLE POUR PORTAIL COULISSANT AUTOPORTANT
- (E) BARRA TENSORA AJUSTABLE PARA PORTÓN EN VOLADIZO
- (P) BARRA DE TENSÃO AJUSTÁVEL PARA PORTÃO CANTILEVER
- (I) TIRANTE DI REGOLAZIONE PER CANCELLO AUTOPORTANTE
- (DK) JUSTERBAR SPÆNDINGSSTANG TIL FRITBÆRENDE PORT
- (NL) VERSTELBARE SPANNINGSBALK VOOR SCHUIFPOORT
- (N) JUSTERBAR STREKKSTANG FOR RULLEPORT
- (S) JUSTERBAR SPÄNNINGSSTÅNG FÖR FRIBÄRANDE GRIND
- (FIN) SÄÄDETTÄVÄ KIRISTYSTANKKO ULOKEPORTTIIN
- (PL) REGULOWANA LISTWA NAPINAJĄCA DO BRAMY SAMONOŚNEJ
- (SK) NASTAVITELNÁ ŤAŽNÁ TYČ PRE SAMONOSNÉ BRÁNY
- (EE) REGULEERITAV PINGUTUSTALA KONSOLVÄRAVA JAOKS
- (LT) REGULIUOJAMA TRAUKĖ GEMBINIAMS VARTAMS
- (LV) REGULĒJAMS STIEPNIS KONSOLVEIDA VARTIEM

- (CZ) TENZNÍ TYČ S REGULACÍ PRO POSUVNOU SAMONOSNOU BRÁNU
- (RO) BARĂ DE TENSIUNE REGLABILĂ PENTRU POARTĂ ÎN CONSOLĂ
- (HR) PRILAGODLJIVA STEZNA ŠIPKA ZA NOSIVA VRATA
- (RUS) БАРА́ DE TENSIUNE REGLABILĂ PENTRU POARTĂ ÎN CONSOLĂ
- (SLO) NASTAVLJIV NAPENJALNI VZVOD ZA SAMONOSNA DRSNA VRATA
- (TR) MANİVELA KAPI İÇİN AYARLANABİLİR GERİLİM ÇUBUĞU
- (AR) قضيب الشد القابل للتعديل لوابية الكابول
- (CHN) 可调节悬臂门拉杆
- (MAL) BAR TEGANGAN BOLEH LARAS UNTUK GET JULUR
- (H) ÁLLÍTHATÓ FESZÍTŐRÚD TOLÓKAPUHOZ
- (IL) מוט מתחיה מתכוון לשיער קרנזווי
- (BG) РЕГУЛИРУЕМ ОБТЕГАЧ ЗА КОНЗОЛНА ВРАТА
- (KO) 캔틸레버 게이트용 조절식 인장대
- (SRB) PODESIVA ZATEZNA ŠIPKA ZA SAMONOSIVU KAPIJU

Art.		L	A min./max.	B	C	D	M	F	1pc			CODE
									kg	pcs	kg	
mm												
<b>DIAGON 60</b>	60x40	260	125 - 170	34	40	40	M20	17	1,39	2	2,78	1700237
<b>DIAGON 80</b>	80x60/60x60	260	125 - 180	54	40	40	M20	17	1,95	2	3,9	1700238

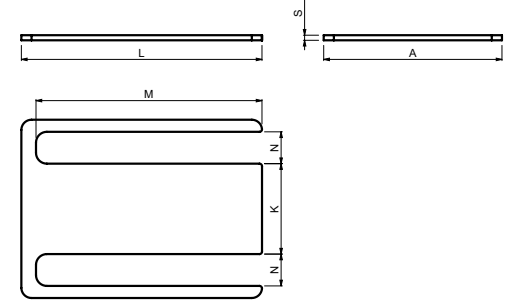
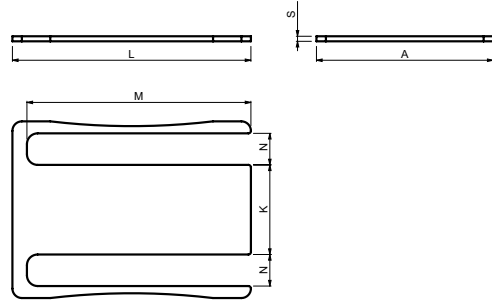
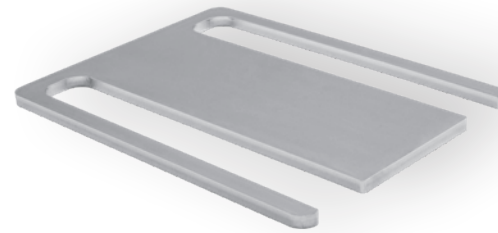
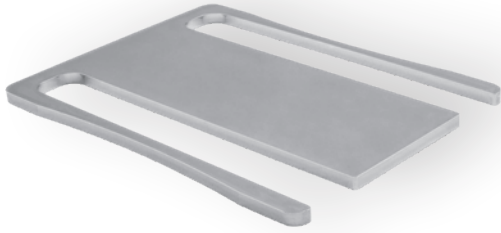



- (GB) WASHER FOR CANTILEVER CARRIAGE
- (D) UNTERLEGSCHIEBE FÜR AUSLEGERSCHLITTEN
- (F) RONDELLE POUR CHARIOT CANTILEVER
- (E) TUERCA PARA CARRO EN VOLADIZO
- (P) ARRUELA PARA TRANSPORTE DE CANTILEVER
- (I) RONDELLA PER CARRELLO CANCELLO AUTOPORTANTE
- (DK) SKIVE TIL FRITBÆRENDE PORT
- (NL) RING VOOR SCHUIFWAGEN
- (N) SKIVE FOR RULLEPORTVOGN
- (S) BRICKA FÖR FRIBÄRANDE GRINDVAGN
- (FIN) ALUSLEVY ULOKETELINEESEEN
- (PL) PODKŁADKA DO WÓZKA BRAMY SAMONOŚNEJ
- (SK) PODLOŽKA PRE SAMONOSNÝ NOSNÍK
- (EE) SEIB KONSOOLALUSE JAOKS
- (LT) POVERŽLĖ GEMBINIŲ VARTŲ VEŽIMĖLIUI
- (LV) PĀPLĀKSNE KONSOLES NESOŠĀJAM RUĻĻU BLOKAM

- (CZ) PODLOŽKA PRO VOZÍK
- (RO) ȘAIBĂ PENTRU SISTEMUL DE CULISARE ÎN CONSOLĂ
- (HR) PODLOŠKA ZA NOSIVO PODVOZJE
- (RUS) ШАЙБА ДЛЯ РОЛИКОВЫХ ТЕЛЕЖЕК САМОНЕСУЩИХ ВОРОТ
- (SLO) PODLOŽKA ZA VOZIČEK
- (TR) MANİVELA TAŞIYICISI İÇİN RONDELA
- (AR) حلبة لوراية الكترول
- (CHN) 悬臂架垫片
- (MAL) SESENDAL UNTUK PEMBAWA JULUR
- (H) ALÁTÉT TOLÓKAPU FUTÓKOCSIHOZ
- (IL) הקרום לנגללים ל'קרונוז'י
- (BG) ВЛОЖКА ЗА КОНЗОЛНА КОЛИЧКА
- (KO) 캔틸레버 이송대용 와셔
- (SRB) PODLOŠKA ZA SAMONOSIVU KAPIJU

- (GB) WASHER FOR CANTILEVER CARRIAGE
- (D) UNTERLEGSCHIEBE FÜR AUSLEGERSCHLITTEN
- (F) RONDELLE POUR CHARIOT CANTILEVER
- (E) TUERCA PARA CARRO EN VOLADIZO
- (P) ARRUELA PARA TRANSPORTE DE CANTILEVER
- (I) RONDELLA PER CARRELLO CANCELLO AUTOPORTANTE
- (DK) SKIVE TIL FRITBÆRENDE PORT
- (NL) RING VOOR SCHUIFWAGEN
- (N) SKIVE FOR RULLEPORTVOGN
- (S) BRICKA FÖR FRIBÄRANDE GRINDVAGN
- (FIN) ALUSLEVY ULOKETELINEESEEN
- (PL) PODKŁADKA DO WÓZKA BRAMY SAMONOŚNEJ
- (SK) PODLOŽKA PRE SAMONOSNÝ NOSNÍK
- (EE) SEIB KONSOOLALUSE JAOKS
- (LT) POVERŽLĖ GEMBINIŲ VARTŲ VEŽIMĖLIUI
- (LV) PĀPLĀKSNE KONSOLES NESOŠĀJAM RUĻĻU BLOKAM

- (CZ) PODLOŽKA PRO VOZÍK
- (RO) ȘAIBĂ PENTRU SISTEMUL DE CULISARE ÎN CONSOLĂ
- (HR) PODLOŠKA ZA NOSIVO PODVOZJE
- (RUS) ШАЙБА ДЛЯ РОЛИКОВЫХ ТЕЛЕЖЕК САМОНЕСУЩИХ ВОРОТ
- (SLO) PODLOŽKA ZA VOZIČEK
- (TR) MANİVELA TAŞIYICISI İÇİN RONDELA
- (AR) حلبة لوراية الكترول
- (CHN) 悬臂架垫片
- (MAL) SESENDAL UNTUK PEMBAWA JULUR
- (H) ALÁTÉT TOLÓKAPU FUTÓKOCSIHOZ
- (IL) הקרום לנגללים ל'קרונוז'י
- (BG) ВЛОЖКА ЗА КОНЗОЛНА КОЛИЧКА
- (KO) 캔틸레버 이송대용 와셔
- (SRB) PODLOŠKA ZA SAMONOSIVU KAPIJU

Art.	L	A	K	M	N	S	CARRIAGE	1pc			CODE
									kg	pcs	
mm											
<b>DESK SE 2</b>	189	140	71	178	25	2	SPEED SE	0,26	6	1,56	1700314
<b>DESK SE 4</b>	189	140	71	178	25	4	SPEED SE	0,52	6	3,12	1700315
<b>DESK SE 6</b>	189	140	71	178	25	6	SPEED SE	0,78	6	4,68	1700316

Art.	L	A	K	M	N	S	CARRIAGE	1pc			CODE
									kg	pcs	
mm											
<b>DESK S 2</b>	189	140	71	178	25	2	SPEED S	0,29	6	1,74	1700317
<b>DESK S 4</b>	189	140	71	178	25	4	SPEED S	0,58	6	3,48	1700318
<b>DESK S 6</b>	189	140	71	178	25	6	SPEED S	0,87	6	5,22	1700319

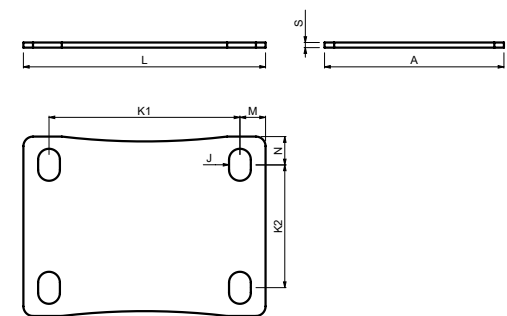
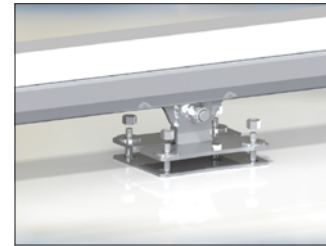
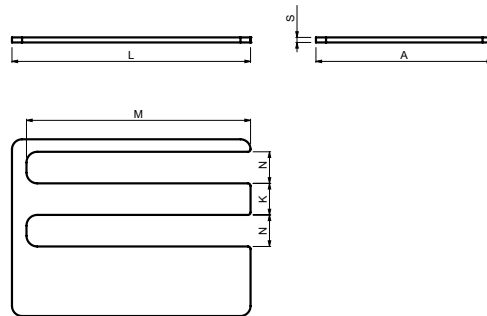
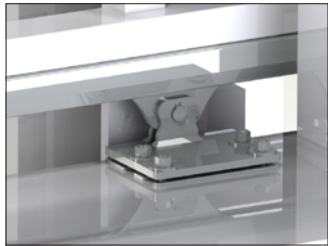
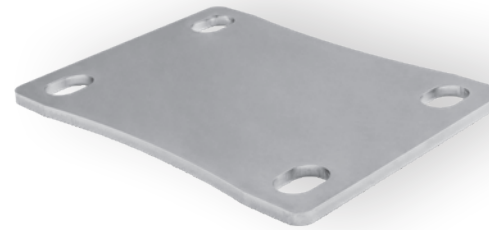
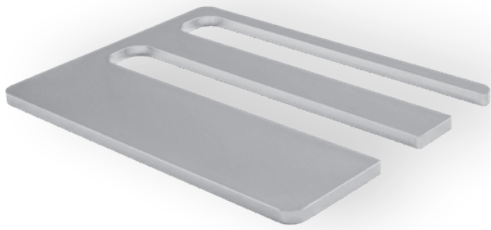



- (GB) WASHER FOR CANTILEVER CARRIAGE
- (D) UNTERLEGSCHIBE FÜR AUSLEGERSCHLITTEN
- (F) RONDELLE POUR CHARIOT CANTILEVER
- (E) TUERCA PARA CARRO EN VOLADIZO
- (P) ARRUELA PARA TRANSPORTE DE CANTILEVER
- (I) RONDELLA PER CARRELLO CANCELLO AUTOPORTANTE
- (DK) SKIVE TIL FRITBÆRENDE PORT
- (NL) RING VOOR SCHUIFWAGEN
- (N) SKIVE FOR RULLEPORTVOGN
- (S) BRICKA FÖR FRIBÄRANDE GRINDVAGN
- (FIN) ALUSLEVY ULOKETELINEESEEN
- (PL) PODKŁADKA DO WÓZKA BRAMY SAMONOŚNEJ
- (SK) PODLOŽKA PRE SAMONOSNÝ NOSNÍK
- (EE) SEIB KONSOOLALUSE JAOKS
- (LT) POVERŽLĖ GEMBINIŲ VARTŲ VEŽIMĖLIUI
- (LV) PĀPLĀKSNE KONSOLES NESOŠAJAM RULĻU BLOKAM

- (CZ) PODLOŽKA PRO VOZÍK
- (RO) ȘAIBĂ PENTRU SISTEMUL DE CULISARE ÎN CONSOLĂ
- (HR) PODLOŠKA ZA NOSIVO PODVOZJE
- (RUS) ШАЙБА ДЛЯ РОЛИКОВЫХ ТЕЛЕЖЕК САМОНЕСУЩИХ ВОРОТ
- (SLO) PODLOŽKA ZA VOZIČEK
- (TR) MANİVELA TAŞIYICISI İÇİN RONDELA
- (AR) حلبة لوراية الكترول
- (CHN) 悬臂架垫片
- (MAL) SESENDAL UNTUK PEMBAWA JULUR
- (H) ALÁTÉT TOLÓKAPU FUTÓKOCSIHOZ
- (IL) חלקה ללגלגים לקונדוליה
- (BG) ВЛОЖКА ЗА КОНЗОЛНА КОЛИЧКА
- (KO) 캔틸레버 이송대용 와셔
- (SRB) PODLOŠKA ZA SAMONOSIVU KAPIJU

- (GB) WASHER FOR CANTILEVER CARRIAGE
- (D) UNTERLEGSCHIBE FÜR AUSLEGERSCHLITTEN
- (F) RONDELLE POUR CHARIOT CANTILEVER
- (E) TUERCA PARA CARRO EN VOLADIZO
- (P) ARRUELA PARA TRANSPORTE DE CANTILEVER
- (I) RONDELLA PER CARRELLO CANCELLO AUTOPORTANTE
- (DK) SKIVE TIL FRITBÆRENDE PORT
- (NL) RING VOOR SCHUIFWAGEN
- (N) SKIVE FOR RULLEPORTVOGN
- (S) BRICKA FÖR FRIBÄRANDE GRINDVAGN
- (FIN) ALUSLEVY ULOKETELINEESEEN
- (PL) PODKŁADKA DO WÓZKA BRAMY SAMONOŚNEJ
- (SK) PODLOŽKA PRE SAMONOSNÝ NOSNÍK
- (EE) SEIB KONSOOLALUSE JAOKS
- (LT) POVERŽLĖ GEMBINIŲ VARTŲ VEŽIMĖLIUI
- (LV) PĀPLĀKSNE KONSOLES NESOŠAJAM RULĻU BLOKAM

- (CZ) PODLOŽKA PRO VOZÍK
- (RO) ȘAIBĂ PENTRU SISTEMUL DE CULISARE ÎN CONSOLĂ
- (HR) PODLOŠKA ZA NOSIVO PODVOZJE
- (RUS) ШАЙБА ДЛЯ РОЛИКОВЫХ ТЕЛЕЖЕК САМОНЕСУЩИХ ВОРОТ
- (SLO) PODLOŽKA ZA VOZIČEK
- (TR) MANİVELA TAŞIYICISI İÇİN RONDELA
- (AR) حلبة لوراية الكترول
- (CHN) 悬臂架垫片
- (MAL) SESENDAL UNTUK PEMBAWA JULUR
- (H) ALÁTÉT TOLÓKAPU FUTÓKOCSIHOZ
- (IL) חלקה ללגלגים לקונדוליה
- (BG) ВЛОЖКА ЗА КОНЗОЛНА КОЛИЧКА
- (KO) 캔틸레버 이송대용 와셔
- (SRB) PODLOŠKA ZA SAMONOSIVU KAPIJU

Art.	L	A	K	M	N	S	CARRIAGE	1pc			CODE
									kg	pcs	
mm											
<b>DESK SK 2</b>	189	140	25	178	25	2	SPEED SK	0,27	6	1,62	1700320
<b>DESK SK 4</b>	189	140	25	178	25	4	SPEED SK	0,54	6	3,24	1700321
<b>DESK SK 6</b>	189	140	25	178	25	6	SPEED SK	0,81	6	4,86	1700322

Art.	L	A	J	K1	K2	M	N	S	CARRIAGE	1pc			CODE
											kg	pcs	
mm													
<b>RAMP SE 2</b>	189	140	17x25	149	96	20	22	2	SPEED SE	0,38	6	2,28	1700283
<b>RAMP SE 4</b>	189	140	17x25	149	96	20	22	4	SPEED SE	0,75	6	4,5	1700284
<b>RAMP SE 6</b>	189	140	17x25	149	96	20	22	6	SPEED SE	1,08	6	6,48	1700285

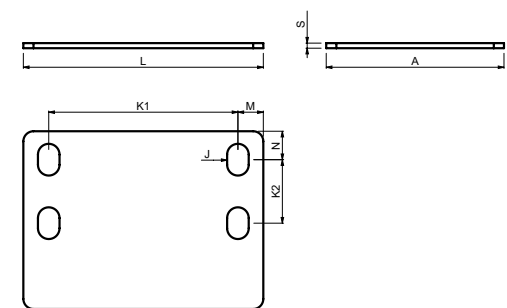
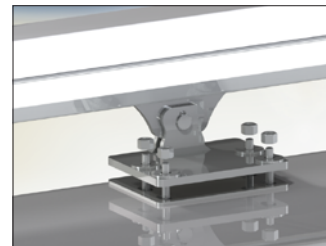
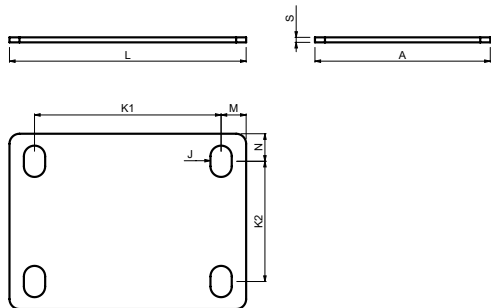
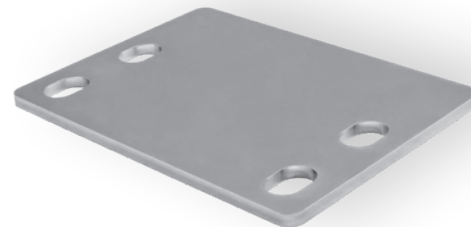
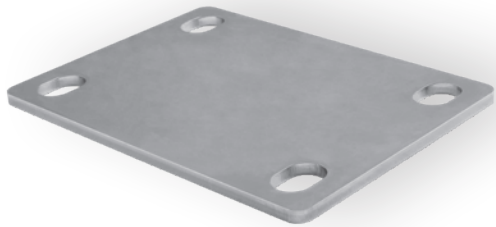

- (GB) WASHER FOR CANTILEVER CARRIAGE
- (D) UNTERLEGSSCHEIBE FÜR AUSLEGERSCHLITTEN
- (F) RONDELLE POUR CHARIOT CANTILEVER
- (E) TUERCA PARA CARRO EN VOLADIZO
- (P) ARRUELA PARA TRANSPORTE DE CANTILEVER
- (I) RONDELLA PER CARRELLO CANCELLO AUTOPORTANTE
- (DK) SKIVE TIL FRITBÆRENDE PORT
- (NL) RING VOOR SCHUIFWAGEN
- (N) SKIVE FOR RULLEPORTVOGN
- (S) BRICKA FÖR FRIBÄRANDE GRINDVAGN
- (FIN) ALUSLEVY ULOKETELINEESEEN
- (PL) PODKŁADKA DO WÓZKA BRAMY SAMONOŚNEJ
- (SK) PODLOŽKA PRE SAMONOSNÝ NOSNÍK
- (EE) SEIB KONSOOLALUSE JAOKS
- (LT) POVERŽLĖ GEMBINIŲ VARTŲ VEŽIMĖLIUI
- (LV) PĀPLĀKSNE KONSOLES NESOŠAJAM RUĻĻU BLOKAM

- (CZ) PODLOŽKA PRO VOZÍK
- (RO) ȘAIBĂ PENTRU SISTEMUL DE CULISARE ÎN CONSOLĂ
- (HR) PODLOŠKA ZA NOSIVO PODVOZJE
- (RUS) ШАЙБА ДЛЯ РОЛИКОВЫХ ТЕЛЕЖЕК САМОНЕСУЩИХ ВОРОТ
- (SLO) PODLOŽKA ZA VOZIČEK
- (TR) MANİVELA TAŞIYICISI İÇİN RONDELA
- (AR) حلبة لوراية الكابول
- (CHN) 悬臂架垫片
- (MAL) SESENDAL UNTUK PEMBAWA JULUR
- (H) ALÁTÉT TOLÓKAPU FUTÓKOCSIHÓZ
- (IL) חוקה לגלגלים קונזולי
- (BG) ВЛОЖКА ЗА КОНЗОЛНА КОЛИЧКА
- (KO) 캔틸레버 이동대용 와셔
- (SRB) PODLOŠKA ZA SAMONOSIVU KAPIJU

- (GB) WASHER FOR CANTILEVER CARRIAGE
- (D) UNTERLEGSSCHEIBE FÜR AUSLEGERSCHLITTEN
- (F) RONDELLE POUR CHARIOT CANTILEVER
- (E) TUERCA PARA CARRO EN VOLADIZO
- (P) ARRUELA PARA TRANSPORTE DE CANTILEVER
- (I) RONDELLA PER CARRELLO CANCELLO AUTOPORTANTE
- (DK) SKIVE TIL FRITBÆRENDE PORT
- (NL) RING VOOR SCHUIFWAGEN
- (N) SKIVE FOR RULLEPORTVOGN
- (S) BRICKA FÖR FRIBÄRANDE GRINDVAGN
- (FIN) ALUSLEVY ULOKETELINEESEEN
- (PL) PODKŁADKA DO WÓZKA BRAMY SAMONOŚNEJ
- (SK) PODLOŽKA PRE SAMONOSNÝ NOSNÍK
- (EE) SEIB KONSOOLALUSE JAOKS
- (LT) POVERŽLĖ GEMBINIŲ VARTŲ VEŽIMĖLIUI
- (LV) PĀPLĀKSNE KONSOLES NESOŠAJAM RUĻĻU BLOKAM

- (CZ) PODLOŽKA PRO VOZÍK
- (RO) ȘAIBĂ PENTRU SISTEMUL DE CULISARE ÎN CONSOLĂ
- (HR) PODLOŠKA ZA NOSIVO PODVOZJE
- (RUS) ШАЙБА ДЛЯ РОЛИКОВЫХ ТЕЛЕЖЕК САМОНЕСУЩИХ ВОРОТ
- (SLO) PODLOŽKA ZA VOZIČEK
- (TR) MANİVELA TAŞIYICISI İÇİN RONDELA
- (AR) حلبة لوراية الكابول
- (CHN) 悬臂架垫片
- (MAL) SESENDAL UNTUK PEMBAWA JULUR
- (H) ALÁTÉT TOLÓKAPU FUTÓKOCSIHÓZ
- (IL) חוקה לגלגלים קונזולי
- (BG) ВЛОЖКА ЗА КОНЗОЛНА КОЛИЧКА
- (KO) 캔틸레버 이동대용 와셔
- (SRB) PODLOŠKA ZA SAMONOSIVU KAPIJU

Art.	L	A	J	K1	K2	M	N	S	CARRIAGE	1pc				CODE
											kg	pcs	kg	
mm														
<b>RAMP S 2</b>	189	140	17x25	149	96	20	22	2	SPEED S	0,4	6	2,4	1700286	
<b>RAMP S 4</b>	189	140	17x25	149	96	20	22	4	SPEED S	0,78	6	4,68	1700287	
<b>RAMP S 6</b>	189	140	17x25	149	96	20	22	6	SPEED S	1,13	6	6,78	1700288	

Art.	L	A	J	K1	K2	M	N	S	CARRIAGE	1pc				CODE
											kg	pcs	kg	
mm														
<b>RAMP SK 2</b>	189	140	17x25	149	50	20	22	2	SPEED SK	0,4	6	2,4	1700289	
<b>RAMP SK 4</b>	189	140	17x25	149	50	20	22	4	SPEED SK	0,78	6	4,68	1700290	
<b>RAMP SK 6</b>	189	140	17x25	149	50	20	22	6	SPEED SK	1,13	6	6,78	1700291	

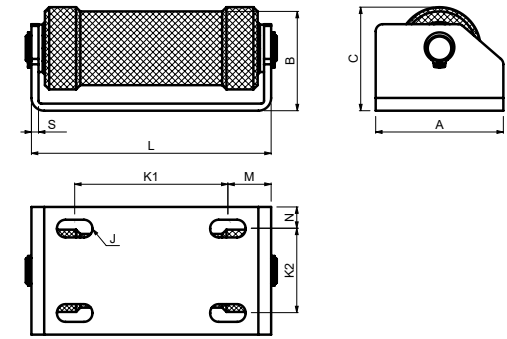
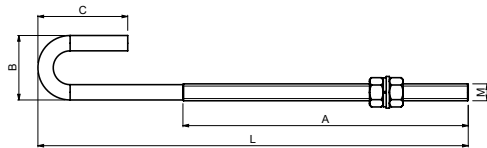
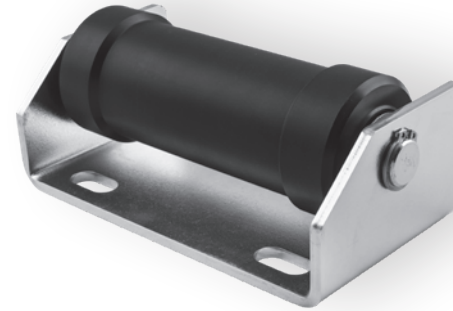
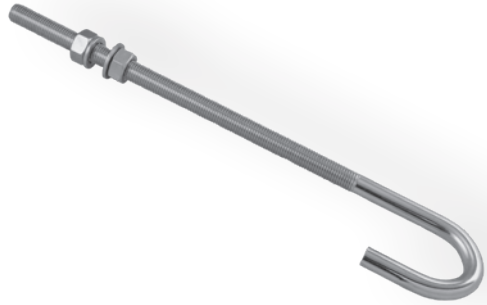

- (GB) FIXING BAR FOR CANTILEVER CARRIAGE
- (D) BEFESTIGUNGSSTANGE FÜR AUSLEGERSCHLITTEN
- (F) BARRE DE FIXATION POUR CHARIOT CANTILEVER
- (E) BARRA DE FIJACIÓN PARA CARRO EN VOLADIZO
- (P) BARRA DE FIXAÇÃO DE TRANSPORTE DE CANTILEVER
- (I) BARRA DI FISSAGGIO PER CARRELLO CANCELLO AUTOPORTANTE
- (DK) FASTGØRSELSSTANG TIL FRITBÆRENDE PORT
- (NL) BEVESTIGINGSBALK VOOR SCHUIFWAGEN
- (N) FESTSTANG FOR RULLEPORT
- (S) FÅSTBALK FÖR FRIBÄRANDE GRINDVAGN
- (FIN) KIINNITYSPALKKI ULOKETELINEESEEN
- (PL) LISTWA MOCUJĄCA DO WÓZKA BRAMY SAMONOŚNEJ
- (SK) UPEVNŔOVACIA TYČ PRE SAMONOSNÝ NOSNÍK
- (EE) FIKSEERIMISTALA KONSOLALUSE JAOKS
- (LT) TVIRTINIMO STRYPAS GEMBINIŲ VARTŲ VEŽIMĖLIUI
- (LV) FIKSĒJOŠAIS STIENIS KONSOLES NESOŠAJAM RUČĻU BLOKAM

- (CZ) FIXAČNÍ TYČ PRO VOZÍK
- (RO) BARĂ DE FIXARE PENTRU SISTEMUL DE CULISARE ÎN CONSOLĂ
- (HR) FIKSIRAJUĆA ŠIPKA ZA NOSIVO PODVOZJE
- (RUS) КРЕПЕЖНЫЙ СТЕРЖЕНЬ ДЛЯ РОЛИКОВЫХ ТЕЛЕЖЕК САМОНЕСУЩИХ ВОРОТ
- (SLO) PRITRDILNI DROG ZA VOZIČEK
- (TR) MANİVELA TAŞIYICISI İÇİN SABITLEME ÇUBUĞU
- (AR) قضيب التثبيت لوابية الكابول
- (CHN) 悬臂架固定条
- (MAL) BAR IKATAN UNTUK PEMBAWA JULUR
- (H) RÖGZÍTŐRŰD TOLÓKAPU FUTÓKOSÍHOZ
- (IL) מסך קיבוע לגלגלי מ ל קונזולי
- (BG) ФИКСАТОР ЗА КОНЗОЛНА КОЛИЧКА
- (KO) 캔틸레버 이송대용 고정대
- (SRB) FIKSIRAJUĆA ŠIPKA ZA SAMONOSIVU KAPIJU

- (GB) SUPPORT ROLLER FOR CANTILEVER GATE
- (D) STÜTZROLLE FÜR AUSLEGERGERT
- (F) ROULEAU DE SUPPORT POUR PORTAIL COULISSANT AUTOPORTANT
- (E) RODILLO DE SOPORTE PARA PORTÓN EN VOLADIZO
- (P) ROLO DE SUPORTE PARA PORTÃO DE CANTILEVER
- (I) RULLO DI SOSTEGNO PER CANCELLO AUTOPORTANTE
- (DK) STØTTERULLE TIL FRITBÆRENDE PORT
- (NL) STEUNROL VOOR SCHUIFPOORT
- (N) STØTTERULLE FOR RULLEPORT
- (S) STÖDROLLE FÖR FRIBÄRANDE GRIND
- (FIN) TUKIRULLA ULOKEPORTTIIN
- (PL) ROLKA DOLNA DO BRAMY SAMONOŚNEJ
- (SK) PODPORNÝ VALEC PRE SAMONOSNÉ BRÁNY
- (EE) TUGIRULLIK KONSOLVÄRAVA JAOKS
- (LT) ATRAMINIS RITINĖLIS GEMBINIAMS VARTAMS
- (LV) BALSTA RULLĪTIS KONSOLVEIDA VĀRTIEM

- (CZ) KONZOLA S KLDKOU PRO PODPĚRU POSUVNÉ SAMONOSNÉ BRÁNY
- (RO) ROLĂ DE SUSȚINERE PENTRU POARTA ÎN CONSOLĂ
- (HR) POTPORNI VALJAK ZA NOSIVA VRATA
- (RUS) ОПОРНЫЙ РОЛИК ДЛЯ САМОНЕСУЩИХ ВОРОТ
- (SLO) PODPORNÍ VALJ ZA SAMONOSNA DRSNA VRATA
- (TR) MANİVELA KAPI İÇİN DESTEK MAKARASI
- (AR) اسطوانة الدعم لوابية الكابول
- (CHN) 悬臂门支撑辊
- (MAL) PENGGELEK SOKONGAN UNTUK GET JULUR
- (H) TARTÓGÖRGŐ TOLÓKAPUHOZ
- (IL) גלגל תמיכה לשער קונזולי
- (BG) ПОДДЪРЖАЩА РОЛКА ЗА КОНЗОЛНА ВРАТА
- (KO) 캔틸레버 게이트용 지지 롤러
- (SRB) NOSEČI VALJAK ZA SAMONOSIVU KAPIJU

Art.	L	A	B	C	M	WASHER	1pc	WASHER			CODE
								kg	pcs	kg	
			mm								
<b>CLINCH 16</b>	410	300	60	80	M16	RAMP	0,72	12	8,64		1700239

Art.	L	A	B	C	J	K1	K2	M	N	S	1pc	WASHER			CODE
												kg	pcs	kg	
			mm												
<b>DRIVESHAFT 80</b>	144	90	70	73	13x25	107	60	31	15	5	1,37	4	5,48		1700332
<b>DRIVESHAFT 100</b>	169	90	70	73	13x25	107	60	31	15	5	1,56	4	6,24		1700333





## EASY SETS



16  
FOLLOW ME



18  
TWIN DRIVE



20  
CHEVRON

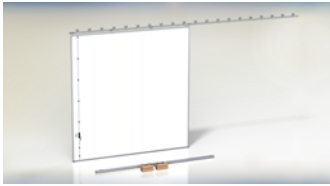

22  
HANGAR



24  
ALL IN ONE



## CANTILEVER S



39  
STAGE SB



39  
STAGE SZ



40  
SPEED SE



40  
SPEED S



41  
SPEED SK



41  
RUN S



42  
LAST S



42  
PARK



42  
PARK 240



43  
Paddock SM



43  
PILOT SN



44  
Paddock 2



44  
Paddock 4

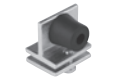

45  
FINISH S



45  
DIAGON 60



45  
DIAGON 80

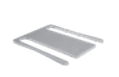

46  
DESK SE



46  
DESK S



47  
DESK SK



47  
RAMP SE



48  
RAMP S



48  
RAMP SK



49  
CLINCH 16



49  
DRIVESHAFT 80



49  
DRIVESHAFT 100



## CANTILEVER M



57  
STAGE MB

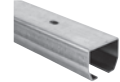

57  
STAGE MZ



58  
SPEED ME



58  
SPEED M



59  
SPEED MEK



59  
RUN M



60  
LAST M



60  
PARK



60  
PARK 240



61  
Paddock SM



61  
PILOT M



61  
PILOT MN



62  
Paddock 2



62  
Paddock 4

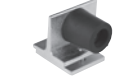

63  
FINISH M



63  
DIAGON 60



63  
DIAGON 80

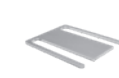

64  
DESK ME



64  
DESK M

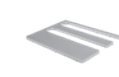

65  
DESK MEK



65  
RAMP ME



66  
RAMP M



66  
RAMP MEK



67  
CLINCH 16



67  
DRIVESHAFT 80



67  
DRIVESHAFT 100



## CANTILEVER L



70  
STAGE LB



70  
STAGE LZ



71  
SPEED L



71  
PILOT L



71  
PILOT LN



72  
RUN L



72  
LAST L



73  
PARK L



73  
PARK L 350



73  
DRIVESHAFT 150



74  
Paddock L



74  
Paddock 6



75  
RAMP L







































































































75  
CLINCH 16



## CANTILEVER SETS



26  
SOLE  
MARE  
VITA  
FERRO  
DINO  
ENZO  
DEMO

	<b>78</b> TRAIL		<b>82</b> WV 1228 B2		<b>84</b> WTV 1024 B2		<b>87</b> WSO 1024		<b>88</b> RB 32		<b>92</b> SFB 42/16		<b>98</b> LOCK L		<b>102</b> LIMIT
	<b>78</b> PIN TRAIL		<b>82</b> WV 1430 B2		<b>85</b> WTO 625		<b>87</b> WSO 824 B2		<b>88</b> RB 42/16		<b>92</b> SFF 2M		<b>98</b> DOCK 42		<b>102</b> LIMIT S
	<b>79</b> ROAD		<b>82</b> WV 1630 B2		<b>85</b> WTO 825		<b>87</b> WSO 924 B2		<b>88</b> RB 42/20		<b>93</b> SFG 4M		<b>98</b> DOCK 52		<b>103</b> LIMIT M
	<b>79</b> PIN ROAD		<b>83</b> WO 824		<b>85</b> WTO 1024 B2		<b>87</b> WSO 1024 B2		<b>89</b> ROB 36		<b>93</b> CRANKSHAFT 220		<b>98</b> DOCK 62		<b>103</b> LIMIT H
	<b>80</b> VECTOR		<b>83</b> WO 924		<b>86</b> WSV 820		<b>87</b> WSO 1228 B2		<b>89</b> ROB 48		<b>93</b> CRANKSHAFT 440		<b>99</b> V/6		<b>104</b> ES 40
	<b>80</b> PIN VECTOR		<b>83</b> WO 1024		<b>86</b> WSV 920		<b>87</b> WSO 1630 B2		<b>89</b> ROB 68		<b>94</b> JRS 30		<b>99</b> S/6		<b>104</b> ES 50
	<b>81</b> VECTOR PACK		<b>83</b> WO 824 B2		<b>86</b> WSV 1020		<b>88</b> RW 26		<b>89</b> REB 36		<b>94</b> JRM 40		<b>99</b> Z/8		<b>104</b> ES 40 PN
	<b>82</b> WV 620		<b>83</b> WO 924 B2		<b>86</b> WSV 824 B2		<b>88</b> RW 30		<b>89</b> REB 48		<b>94</b> PRS 30		<b>99</b> Z/12		<b>104</b> ES 50 PN
	<b>82</b> WV 820		<b>83</b> WO 1024 B2		<b>86</b> WSV 924 B2		<b>88</b> RW 40		<b>89</b> REB 68		<b>94</b> PRM 40		<b>100</b> ROOF B		<b>105</b> END S
	<b>82</b> WV 920		<b>83</b> WO 1228 B2		<b>86</b> WSV 1024 B2		<b>88</b> RR 26		<b>90</b> SR 2		<b>95</b> DRIVER 38		<b>100</b> ROOF S		<b>105</b> END M
	<b>82</b> WV 1020		<b>83</b> WO 1430 B2		<b>86</b> WSV 1228 B2		<b>88</b> RR 30		<b>90</b> FRS 2		<b>95</b> DRIVER 48		<b>101</b> DUNE 2		<b>105</b> END L
	<b>82</b> WV 824 B2		<b>83</b> WO 1630 B2		<b>86</b> WSV 1630 B2		<b>88</b> RR 40		<b>90</b> FRM 2				<b>101</b> DUNE 2L		<b>105</b> END O
	<b>82</b> WV 924 B2		<b>84</b> WTV 624		<b>87</b> WSO 824		<b>88</b> RB 26		<b>91</b> GRS 4						
	<b>82</b> WV 1024 B2		<b>84</b> WTV 824		<b>87</b> WSO 924		<b>88</b> RB 30		<b>91</b> GRM 4						



# About Us

We are dedicated to making the best cantilever and sliding gate hardware. Since inception direction towards to the highest quality is our driving force. This can be seen with the dedication and passion of the workforce. This can be seen in the packaging. This can be seen in the care and attention to the smallest details. As it's this detail on hardware that can make all the difference in the lifespan of the product and the electric motors that power them.

Following extensive research and development **CAIS** is now in the enviable position of offering the highest quality product available for the gate market. We have worked with a renowned BRNO UNIVERSITY OF TECHNOLOGY - FACULTY OF MECHANICAL ENGINEERING, looking at the way the load is transferred throughout the wheels, bearings and carriages whilst under stress of a moving gate.

The results surprised and inspired us to reinvent our product, to become more accurate and search intensively for a steel supplier that can match our ambitions.

We searched for galvanised steel that doesn't crack under rolling, we searched for steel of the correct tolerances and chemical composition.

We found all this and more with our German Supplier WUPPERMANN and created something very impressive.

CAIS also invested heavily in what is the heart of our company, a brand new roll forming line.

With uniquely, 18 large precision formed rollers that allow minute differences to be made until the rolling is perfectly straight and accurate to our own exact standards.



## State Of The Art Roll Forming Line

**Eighteen Roll Formers** - The best in the industry to remove the inset "memory" of the metal.  
**Built in flying hole punch** - Punches a hole in the rail exactly every 400 mm.  
**Slow rolling** - This means no heat during the production keeping the material where it is rolled with no "relaxation" of the product after.

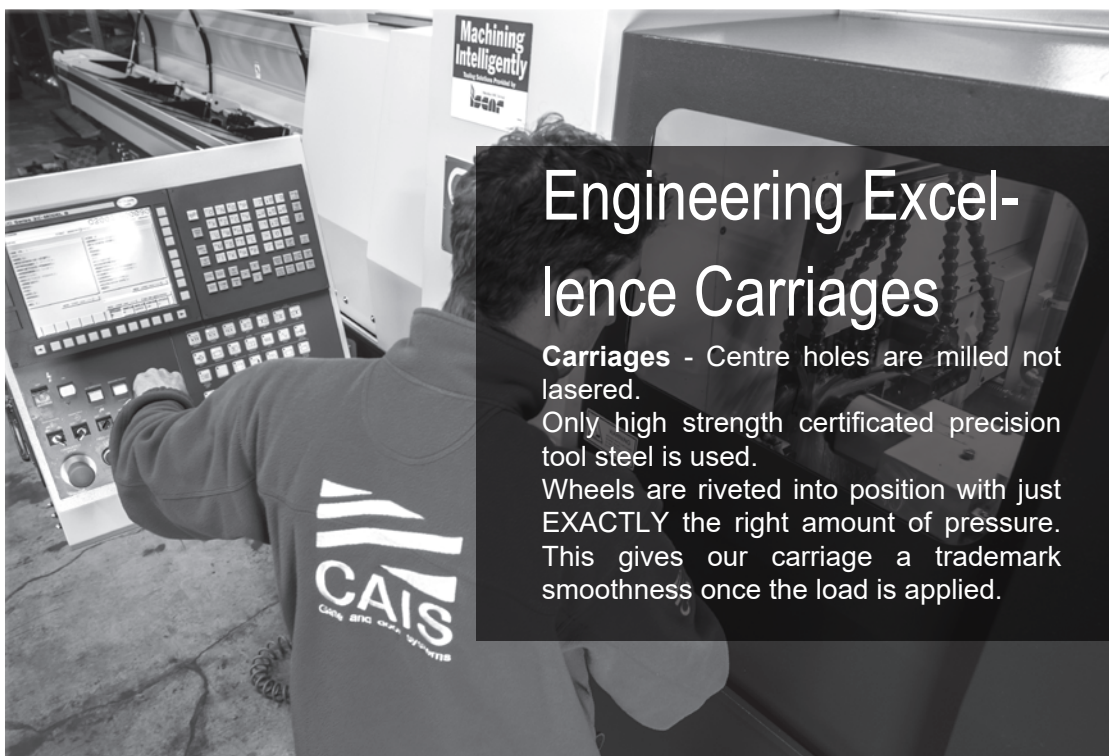

## Engineering Excellence Carriages

**Carriages** - Centre holes are milled not lasered.  
Only high strength certificated precision tool steel is used.  
Wheels are riveted into position with just EXACTLY the right amount of pressure. This gives our carriage a trademark smoothness once the load is applied.

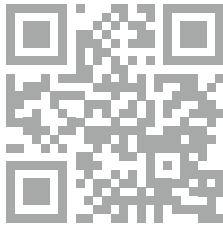

[www.cais.eu](http://www.cais.eu)